

**RTÉ TRANSMISSION NETWORK DAC**

**WHOLESALE ACCESS REFERENCE OFFER**

---

**MARKET A – NATIONAL TERRESTRIAL RADIO AND  
TELEVISION BROADCASTING SERVICES AGREEMENT**

---

SUBJECT TO CONTRACT/CONTRACT DENIED

The following document is RTE/2RN's "wholesale access reference offer" ("**WARO**") published pursuant to ComReg's Decision Notice D02/26. This document does not constitute an offer capable of acceptance or a template contract intended to act as a first draft for negotiations. It is a reference document so that third parties seeking wholesale access to either national terrestrial broadcast transmission services ("**Market A**") or DTT multiplexing services ("**Market B**") can gain an overview and understanding of the form of agreement they will be required to enter. It is RTE and 2RN's intention that the majority of its wholesale broadcasting services agreements would be in substantially the same format as this reference document. However individual negotiations may lead to amendments for particular applicants on a case by case basis. For example agreements requiring the roll out of additional network infrastructure or concerns RTE or 2RN may have in relation to the credit worthiness of a particular client may require the satisfaction of certain specific pre-conditions prior to entering into the agreement or the inclusion of any number of provisions within the agreement or its Appendices. The services covered by this WARO are strictly limited to those services necessary to comply with ComReg's Decision Notice D02/26.



**DATED ●**

**RTÉ TRANSMISSION NETWORK DAC**

**AND**

**[CLIENT]**

---

**MARKET A – NATIONAL TERRESTRIAL RADIO AND  
TELEVISION BROADCASTING SERVICES AGREEMENT**

---

**SUBJECT TO CONTRACT/CONTRACT DENIED**

**TABLE OF CONTENTS**

1	INTERPRETATION .....	5
2	SCOPE OF SERVICES .....	9
3	TERM .....	10
4	THE SYSTEM .....	10
5	TARIFF AND PAYMENT .....	11
6	WARRANTIES AND UNDERTAKINGS .....	12
7	MONITORING AND MAINTENANCE .....	14
8	CHANGE CONTROL .....	14
9	LIABILITY, INDEMNIFICATION AND INSURANCE .....	15
10	CLIENT LIABILITY AND INDEMNITIES .....	17
11	LICENCES .....	18
12	AMENDMENTS, VARIATIONS AND RELIANCE ON INSTRUCTIONS .....	18
13	SITE ACCESS .....	19
14	CONFIDENTIALITY .....	19
15	SCOPE OF AUTHORITY .....	21
16	NO PARTNERSHIP OR AGENCY .....	21
17	INTELLECTUAL PROPERTY .....	21
18	TERMINATION .....	21
19	ASSIGNMENT AND SUB-CONTRACTING .....	23
20	ENTIRE AGREEMENT .....	23
21	DISPUTES AND MEDIATION .....	23
22	VALIDITY AND WAIVER .....	25
23	FORCE MAJEURE.....	25
24	COSTS.....	26
25	COMPLIANCE WITH STATUTE .....	26
26	SEVERANCE .....	26
27	NOTICES .....	26
28	GOVERNING LAW AND JURISDICTION.....	27

**Appendix A**  
Service Schedules

**Appendix B**  
Tariffs

**Appendix C**  
Roll Out Plan

**THIS AGREEMENT** is made on the ● day of ● 20 ●

**BETWEEN**

- (1) **RTÉ TRANSMISSION NETWORK DAC, trading as 2RN**, a company registered in Ireland under number 364909, having its registered office at Montrose, Donnybrook, Dublin 4 (the “**Service Provider**”, which expression shall include its successors and permitted assigns); and
- (2) ● of ● (the “**Client**” which expression shall include its successors and permitted assigns).

**BACKGROUND**

- A. 2RN operates a national terrestrial broadcasting distribution and transmission network. In ComReg Decision D11/13 of 26 July 2013, ComReg found that 2RN had Significant Market Power in the market for wholesale access to national terrestrial broadcast transmission services (“**Market A**”) and imposed on 2RN certain obligations including obligations of access, non-discrimination, transparency, cost-orientation and accounting separation.
- B. The Client is a Digital Terrestrial Multiplex Operator or an Analogue National or Quasi-National Radio Broadcaster licensed under the Broadcasting Act, 2009 who requests access to 2RN’s national broadcasting distribution and transmission network for the provision of content to end-users.
- C. The Client has requested the Service Provider to provide certain wholesale broadcasting services which the Service Provider has agreed to do on the terms hereinafter contained.

**WHEREBY IT IS AGREED** as follows:-

**INTERPRETATION**

1.1 In this Agreement the following words or expressions shall where the context so admits or requires have the following meanings:

“**Agreement**” means this Agreement and any Appendices or Schedules thereto;

“**Authorised Representative**” means the person nominated by each Party for the purposes of managing this Agreement and with the authority to bind such Party which for the Service Provider shall be the Executive Director of 2RN for the time being and for the Client shall be the ● of the Client for the time being;

“**BAI**” means the Broadcasting Authority of Ireland or anybody which, under statute or order, now or at any time performs any of the roles or responsibilities now undertaken by the BAI;

“**Broadcasting Acts**” means the Broadcasting Acts 1926 to 2009;

“**Change Control Procedure**” shall have the meaning given in Clause 8.1;

“**Change of Control**” means,

- (a) any alteration in the ownership structure of a party to this Agreement or of a permitted assignee which results in the transfer from one person or a group of persons acting in concert to another person or group of persons acting in concert, the direct or indirect power (a) to vote or direct the voting of more than fifty (50) per cent of the shares in the party (or permitted assignee, if applicable) having rights to attend and vote on the appointment or election of Directors at general meetings of a party (or permitted assignee, if applicable), or (b) to direct or cause the direction of the management and policies of a party (or permitted assignee, if applicable); or
- (b) a disposal, sale or conveyance or lease or parting with control by a party (or permitted assignee, if applicable) of the whole or substantially the whole of its property, assets or undertaking;

**“Competent Authority”** means and includes any governmental, regulatory or quasi-regulatory body or any court of competent jurisdiction or arbitrator, and any other Minister, body or undertaking, whether established by statute or otherwise, and whether being of a public or private nature or otherwise, including, but not limited to, any international or supranational agency or body, with the power and competence to make decisions, awards, rulings, judgements, decide claims, issue notices or otherwise and which are binding on the Parties or either of them);

**“ComReg”** means the Commission for Communications Regulation or any body which, under statute or order, now or at any time performs any of the roles and responsibilities now undertaken by ComReg;

**“Confidential Information”** shall have the meaning given in Clause 14.1(a);

**“Content Transport Stream”** means the electronic form in which the Content is supplied to the Interface Point and which shall have the specifications set out in Appendix A;

**“Content”** means any audio visual content or data which the Client has requested the Service Provider to broadcast pursuant to this Agreement;

**“Documentation”** means a description of the Services, technical specifications, manuals, process definitions and procedures, as may be required by the Client in order to use the Services;

**“DTT”** means Digital Terrestrial Television;

**“Effective Date”** means the date on which the Service Provider shall commence the provision of the Services to the Client, which date shall be no later than ● 20●;

**“Emergency Maintenance”** means work which is required at short (or no) notice due to an unexpected, unpredictable, or impending Fault and which must be carried out immediately upon appearance of the Fault in order to maintain or restore operation of either the System or a system or equipment not used by the Service Provider but co-located on a Site used by the Service Provider;

**“Equipment”** means the equipment necessary for the provision of the

Services;

“**EUR**” or “**€**” means the lawful currency for the time being of Ireland;

“**EURIBOR**” means the annual rate of interest which appears on Telerate page 249 (two hundred and forty nine) or any equivalent successor to any such page, as appropriate, (as determined by the Service Provider) (each a “**Telerate Screen**”) at or about 11:00 am Dublin time for such specified period as being the rate offered in the Euro interbank market for the offering of deposits in Euro for the specified period and for the purposes of this definition “**specified period**” means the period in respect of which EURIBOR falls to be determined in relation to such sum;

“**Expert**” shall have the meaning given in Clause 21.5;

“**Failure Thresholds**” means the thresholds defined in Appendix A;

“**Fault**” means when the System Service Delivery Requirements as set out in Section 2 of Appendix A are not met;

“**Force Majeure**” has the meaning set out in Clause 23;

“**Group**” means a Party, its holding company or companies and the subsidiaries of all of them;

“**Initial Term**” shall have the meaning given in Clause 3;

“**Intellectual Property Rights**” means all rights to and relating to copyright (including moral rights and all rights relating to the Content), patents, inventions (patentable or otherwise), registered or unregistered designs, trademarks and service marks (whether registered or unregistered), and all applications for patents, trademarks, service marks and designs, topography rights, semiconductor rights, trade secrets, know-how, rights of confidence, database rights, and any other intellectual or industrial property rights of whatsoever nature, whether similar to those described above or otherwise and whether existing or prospective throughout the world;

“**Indemnity Claim Notice**” shall have the meaning given in Clause 10.5;

“**Interface Points**” are the points of presentation of the Content for connection to the System required in connection with the provision of the Services;

“**Ireland**” means the island of Ireland, excluding Northern Ireland;

“**Party**” means each of the Service Provider and the Client;

“**Planned Maintenance**” means work which is not Emergency Maintenance and which is required either to ensure that the System, Equipment and facilities are maintained in reasonable repair and condition or to enable new or replacement equipment to be safely installed;

“**Pre-contractual Statement**” shall have the meaning given in Clause 20.1;

“**Quarter Days**” means 31 March, 30 June, 30 September and 31 December

in each calendar year;

“**Regular Hours**” means *[06:30 to 23:30]* every day of a year;

“**Relevant Item**” shall have the meaning given in Clause 4.8;

“**Roll Out Plan**” means, if applicable, the plan setting out the dates on which it is intended that any additional elements of the System will be completed, as set out in Appendix A;

“**Security**” means such security obligations, if any, as the Service Provider may impose on the Client in further consideration for providing the Services and as shall be agreed between the Parties and set out in Appendix A;

“**Service Availability Target**” shall have the meaning given in Appendix A:

“**Service Credits**” means the sums payable by the Service Provider to the Client in the event the Service fails to meet the Service Availability Target, as specified in Appendix A;

“**Service**” shall be the services to be provided by the Service Provider to the Client as referred to in Clause 2 and as more particularly described in Appendix A;

“**State**” means the island of Ireland (excluding Northern Ireland);

“**Station**” or “**Site**” or “**site**” means a site containing Equipment necessary for the purpose of providing the Services;

“**System**” means the multiplexing, distribution, transmission systems and all other systems, equipment and services necessary to provide the Services;

“**Tariff**” means, subject to Clause 5.4, those tariffs set out and calculated in the manner specified in Appendix B payable by the Client to the Service Provider in consideration for the Services;

“**Tariff Model**” means the model based upon which the Service Provider calculates the Tariff from time to time;

“**Term**” shall have the meaning given in Clause 3;

“**Termination Date**” means the date of termination of this Agreement;

“**Termination Sum**” means the percentage of the Tariff payable by the Client to the Service Provider pursuant to Clause 18.4 and as set out in Appendix B; and

“**Third Party Claim**” shall have the meaning given in Clause 10.5.

1.2 In this Agreement, unless the context otherwise requires:

(a) a reference to:

(i) any Party includes its successors in title and permitted assigns;

- (ii) a “person” includes any individual, firm, body corporate, association or partnership, government or state or agency of a state, local authority or government body or any joint venture association or partnership (whether or not having a separate legal personality);
  - (iii) a “company” shall be construed so as to include any company, corporation or body corporate, wherever and however incorporated or established;
  - (iv) a Clause unless otherwise specified, is a reference to a Clause of this Agreement;
  - (v) writing or similar expressions includes, unless otherwise specified, transmission by facsimile and includes email;
  - (vi) the singular include the plural and vice versa and references to one gender includes all genders;
  - (vii) “day” or a “Business Day” shall mean a period of twenty-four (24) hours running from midnight to midnight;
  - (viii) a “month” shall mean a calendar month;
  - (ix) times are to time in Ireland; and
  - (x) any other document referred to in this Agreement is a reference to that document as amended, varied, novated or supplemented at any time,
- (b) a reference to a statute or statutory provision shall be construed as a reference to the same or it may have been, or may from time to time be amended, modified or re-enacted;
  - (c) any phrase introduced by the terms “including”, “include” and “in particular” or any similar expression shall be construed as illustrative and shall not limit the sense of the words preceding those terms.
- 1.3 The table of contents and headings in this Agreement are inserted for convenience only. They are to be ignored in the interpretation of this Agreement.

## **SCOPE OF SERVICES**

- 2.1 The Service Provider agrees to provide the Services to the Client for the Term in consideration for the Tariff, subject to compliance by the Client with its obligations under this Agreement including, but not limited to, putting in place and maintaining any Security.
- 2.2 It is hereby agreed and acknowledged by the Client that the System and all its components belong absolutely to the Service Provider and the Client has and will have no interest or title of any kind therein.
- 2.3 The Client shall use the System and shall not engage a party other than the Service Provider to provide the Services during the Term.

- 2.4 Each party shall respond promptly to the other for all requests for instructions, information or assistance relating to the Services, as the case may be.

## TERM

This Agreement shall commence on the date of execution of this Agreement and shall continue until expiry, termination by agreement or in accordance with the provisions for early termination pursuant to Clause 18) and subject to any minimum period set out in Appendix A (the “**Initial Term**”). Prior to the expiry of the Initial Term, the Parties may agree to extend the term for successive terms of the duration referred to in Appendix A (the “**Term**”).

## THE SYSTEM

- 4.1 The Service Provider shall provide the System substantially in accordance with Appendix A and, subject to Clause 4.6 and Clause 8, any other relevant technical standards notified by any Competent Authority to the Service Provider or to the Client from time to time) and if applicable, in accordance with the Roll Out Plan.
- 4.2 The Service Provider shall provide or procure the provision of the Services and the System. The Client shall provide such material for test transmissions by the Service Provider as the Service Provider considers reasonably appropriate.
- 4.3 The Client shall not be entitled to challenge the completion of the installation of the System at any Site for any reason other than the failure of the requisite tests in compliance with Appendix A.
- 4.4 If at any time the Service Provider is of the view that any date in the Roll Out Plan, if any, will not be met, then it will promptly advise the Client.
- 4.5 The Service Provider will keep the Client reasonably informed of progress of the planning and the installation of any Roll Out Plan, if any.
- 4.6 The Service Provider acknowledges that it may become appropriate for modifications to the technical requirements of the System to be made during the Term and that requests for changes must be made by the Client in accordance with the Change Control Procedure.
- 4.7 The Service Provider may substitute any Site or Equipment (in each case, a “**Relevant Item**”) as required and, in the case of any Equipment, after consultation with, and taking due account of any legitimate concerns of, the Client (save where, in the case of Equipment, the substitution forms part of standard first-line corrective maintenance practice to exchange a faulty unit with a replacement of identical or reasonably equivalent functionality).
- 4.8 The Client acknowledges that the Service Provider is only a licensee of some Sites and that if the owner of any Site wishes to dispose of, or decommission it, the Service Provider’s licence may be terminated. In the event a licence is to be terminated, the Service Provider shall as soon as is reasonably practicable after it has become aware of such fact, notify the Client of such proposed termination. The Service Provider will use reasonable endeavours to ensure that any substitute Site or Equipment shall be broadly equivalent to and in any event not result in a material degradation of service from the service previously available from the Site or Equipment being replaced.

## TARIFF AND PAYMENT

- 5.1 In consideration of the Services being provided by the Service Provider the Client shall pay to the Service Provider the Tariffs calculated in accordance with the provisions of Appendix C against invoices submitted to the Client.
- 5.2 The Tariffs will be payable quarterly in advance with effect from the Effective Date and will be invoiced by way of four invoices of equal amount, one issued on each of the Quarter Days. The Tariff is exclusive of Value Added Tax or other similar tax. Any Service Credits payable pursuant to Appendix A shall be deducted quarterly in arrears with effect from the Effective Date. The Parties agree and acknowledge that any Service Credits payable hereunder are liquidated damages and a genuine and reasonable pre-estimate of the loss or damage that would be suffered by the Client in the event that the Service Provider fails to meet the Service Availability Target.
- 5.3 If the Client requests in writing that the Service Provider carries out additional work and the Service Provider agrees to perform such work at a cost to be agreed, the Service Provider's charges shall be calculated by reference to the Service Provider's reasonable prevailing standard rates of charge.
- 5.4 If any sum properly invoiced and payable under this Agreement is not paid by the Client within 30 calendar days of the date of receipt of the invoice, the Service Provider reserves the right to:
- (a) charge interest from the due date of payment to the actual date of payment at the annual rate of seven per cent. (7%) above EURIBOR from time to time in force; and/or
  - (b) issue a notice in writing to the Client noting the late payment and advising the Client that if the outstanding sum is not paid within a period of seven (7) days from the date of such notice, the Service Provider may, without any liability to the Client whatsoever and without any further notice, reduce the output power of the Service at each Site to fifty per cent (50%) of Output Power (ERP) as detailed in Appendix A, Table 1.
  - (c) if, following the issuance of a notice by the Company pursuant to Clause 5.4(b), due sums remain unpaid after a further period of seven (7) days from the date of the notice, the Company may, without any liability to the Client whatsoever and without any further notice, reduce the output power of the Service at each site to twenty five per cent (25%) of Output Power (ERP) as detailed in Appendix A, Table 1.
  - (d) if, following the issuance of a notice by the Company pursuant to Clause 5.4(b), due sums remain unpaid after a further period of fourteen (14) days from the date of the notice, the Company may, without any liability to the Client whatsoever, and without any further notice, reduce the output power of the Service at each site to fifteen per cent (15) of Output Power (ERP kW) as detailed in Appendix A, Table 1.
  - (e) if, following the issuance of a notice by the Company pursuant to

Clause 5.4(b), due sums remain unpaid after a further period of twenty one (21) days from the date of the notice, the Company may, without any liability to the Client whatsoever and without any further notice, cease immediately to provide the Service and this Agreement shall be terminated with immediate effect.

- 5.5 If the cost to the Service Provider of performing its obligations under this Agreement shall change by reason of an obligation being placed on the Service Provider as a result of any amendment, extension, enactment or re-enactment of any law after the date of this Agreement or if the Service Provider is required to carry out any further work in order to comply with any change(s) to ComReg requirements, BAI requirements, or any other changes to its legal obligations directly applicable to this Agreement which arise after the date of the Agreement:
- (a) then the Service Provider shall, as soon as reasonably practicable after it becomes aware of any such change which might affect the Tariff or which may necessitate a change in the System, or the Roll Out Plan, provide reasonable details of same to the Client;
  - (b) the Service Provider shall provide to the Client reasonable information in the possession of the Service Provider in relation to the relevant change and the Client shall have the opportunity to make such observations and representations and raise such objections with any Competent Authority as it thinks fit in this regard and the Service Provider shall provide to the Client the opportunity for the Client to participate in negotiations, consultations, discussions, or any other relevant process in relation to the change;
  - (c) in the event that such a change does result in a change to the Tariff, then the amount of any consequent increase or decrease in the Tariffs shall be notified to the Client, together with reasonable documentary evidence of the basis for such change in costs;
  - (d) the Client shall meet any increased costs to the Service Provider referred to above and such changes in the Tariff shall be made by way of a corresponding adjustment to the calculation of the Tariffs;
- 5.6 Each year the Service Provider may revise the Tariff and it undertakes to apply any changes to its costs on a fair and equitable basis to the Client. It is expected that revisions in the Tariff shall be in the normal course of events be made by no later than 1<sup>st</sup> November in each year to take effect the following January. In addition to this revision, the Service Provider shall be entitled to revise its Tariff schedule in the event that exceptional events occur, provided however that any application of charges shall again be on a fair and equitable basis to the Client, and upon prior notification of the revisions by way of publication on the Service Provider's website.

## **WARRANTIES AND UNDERTAKINGS**

- 6.1 The Service Provider warrants to the Client that:
- (a) it is validly existing under the laws of Ireland;

- (b) the execution and delivery of this Agreement, and the performance by the Service Provider of its obligations under it, will not:
  - (i) result in a breach of, or constitute a default under, any instrument to which it is a party or by which they are bound; or
  - (ii) result in a breach of any order, judgment or decree of any court, governmental agency or regulatory body to which they are a party or by which they are bound; or
  - (iii) require the consent of any other person;
- (c) it has the requisite power and authority to enter into and perform this Agreement; and
- (d) The System shall be designed, installed, tested and operated with the degree of skill and care reasonably expected by the broadcast service industry standards prevailing at the time the relevant service is being performed.

6.2 The Service Provider agrees that:

- (a) unless otherwise agreed in writing by the Client, the Service Provider shall not, save where expressly required to do by any Competent Authority, interrupt, alter, add to, delete, edit, overlay, frame or shrink any part of the Content; and
- (b) insofar as the Client may be under an obligation to provide reports to the Competent Authority concerning its performance, provide the Client (at the Client's cost and expense) with reasonable assistance and information required to enable the Client to prepare such reports.

6.3 The Client warrants and represents to the Service Provider that:

- (a) it is a company duly incorporated and validly existing under the laws of Ireland;
- (b) the execution and delivery of this Agreement, and the performance by it of its obligations under it, will not:
  - (i) result in a breach of, or constitute a default under, any instrument to which it is a party or by which it is bound; or
  - (ii) result in a breach of any order, judgment or decree of any court, governmental agency or regulatory body to which it is a party or by which it is bound; or
  - (iii) require the consent of its shareholders or of any other person.
- (c) it is not engaged in any litigation or arbitration proceedings which might have an effect upon its capacity or ability to perform its obligations under this Agreement and no such legal or arbitration proceedings are threatened;

- (d) it has the requisite power and authority to enter into and perform this Agreement;
- (e) this Agreement constitutes and imposes valid legal and binding obligations on it fully enforceable in accordance with its terms;
- (f) the Client has obtained all necessary licences, authorities, permissions, consents and approvals in respect of the Client Programme Content and such licences, authorities, permissions, consents, and approvals are and will be valid and subsisting for the duration of this Agreement;
- (g) the Client has in place the financial security as specified in Appendix B, if any; and
- (h) the broadcasting of the Content by the Service Provider will not result in an infringement of any third party's Intellectual Property Rights.

6.4 The Client and the Service Provider undertake that:

- (a) each of them shall promptly provide the other with all information the other Party reasonably requires from time to time to facilitate the proper and timely discharge of that other Party's obligations under this Agreement; and
- (b) each of the Client and the Service Provider shall maintain a dialogue with respect to the Services and potential provision of augmentations, improvements or additions to such Services on such terms as may be agreed.

#### **MONITORING AND MAINTENANCE**

- 7.1 The Service Provider shall have in place monitoring, maintenance and fault diagnosis of the System and remote control of the Equipment.
- 7.2 The Service Provider shall be entitled, without liability, to interrupt or suspend the Services in order to carry out such Emergency Maintenance and Planned Maintenance as is required to maintain the integrity and the reliability of the System or Services or as requested or required by any Competent Authority. Where practicable the Service Provider shall provide the Client with reasonable notice of such Emergency Maintenance and will notify the Client of any Planned Maintenance that requires operation outside the Failure Thresholds.

#### **CHANGE CONTROL**

- 8.1 Subject to Clauses 8.2 and 8.3, no change may be made to this Agreement (including any Appendix or Schedule) unless agreed in advance by the Parties and made in writing and signed by the Authorised Representatives of the Parties in accordance with this Clause 8 (the "**Change Control Procedure**").
- 8.2 The provisions of this Clause 8 shall not apply to revisions to the Tariff made pursuant to Clause 5.
- 8.3 Either Party shall be entitled to make the following changes to the Agreement without reference to the Change Control Procedure, on prior written notice to

the other Party:

- (a) replacing the Authorised Representative;
- (b) amending or updating the notice details; or
- (c) as required by a Competent Authority.

8.4 A change request must be made in writing and, in relation to any change request by the Service Provider or the Client, the other relevant Party shall then provide:

- (a) an indication of the technical design (if any) required in order to implement the proposed change;
- (b) details of any technical ramifications which would result from adoption of the change;
- (c) details of the consequences of failing to adopt the proposed change;
- (d) best estimate of any financial implications and whether or not it is proposed that these will be absorbed by the Service Provider or the Client within the Tariff (and if so, to what extent);
- (e) the proposed timescale for implementation of the change;
- (f) any additional information the Service Provider or the Client requires in order to finalise the information provided in response to the change request;

8.5 The Service Provider or the Client (as the case may be) will process requests for a change (whether such requests originate from the Client or the Service Provider) within 30 days of the request having first been communicated (or as otherwise agreed from time to time). It is recognised that minor changes should be processed more quickly but that major changes may be subject to a longer agreed time scale.

8.6 The Service Provider shall log all change requests together with the status of ensuing actions and, on request, provide a copy of the log to the Client.

#### **LIABILITY, INDEMNIFICATION AND INSURANCE**

9.1 Each Party's obligations and liabilities to the other arising out of or in connection with the provision of the Services and any other services provided hereunder shall be only those expressly set out in this Agreement together with those obligations which are implied by law but only to the extent that they cannot be restricted, limited or excluded;

9.2 Either Party's aggregate liability in contract, tort or otherwise for breaches of its duties to the other Party arising by reason of or in connection with this Agreement shall be limited to €5,000,000 in any year of the Term.

9.3 Subject to Clause 9.2, the Service Provider shall have no liability to the Client for any damage or loss of whatsoever nature (including, but not limited to, direct and indirect loss, economic loss, consequential loss, loss of business,

loss of revenue, loss of contracts, loss of profits, loss of goodwill and/or loss of reputation) whether arising under contract, statute, tort, in equity or common law, and for any claims, demands, awards, costs and expenses of whatsoever nature whether arising pursuant to this Agreement or otherwise.

- 9.4 Nothing in this Agreement shall exclude or restrict:
- (a) a Party's liability for physical damage to property, fraud or other criminal act, or for death or personal injury resulting from its own, or its sub-contractor's negligence or other tort; or
  - (b) losses which are the result of any deliberate breach of this agreement by a Party or its employees, agents or subcontractors or any breach of this agreement that results from the wilful act or wilful omission of a Party or its employees, agents or subcontractors.
- 9.5 The Service Provider undertakes and agrees to take out and maintain the following insurances with reputable insurers for the following terms:
- (a) Employer's liability insurance for an amount of not less than €13,000,000 for each and every claim to be maintained at all times during the Term;
  - (b) Public/Products liability insurance for an amount of not less than €6,500,000 for each and every claim to be maintained at all times during the Term;
  - (c) Professional indemnity insurance for an amount of not less than €5,000,000 for any one claim to be maintained at all times during the Term and for a period of seven years following the expiration or termination of this Agreement for whatever reason.
- 9.6 The Client undertakes and agrees to take out and maintain the following insurances with insurers approved by the Institute for the following terms:
- (a) Employer's liability insurance for an amount of not less than €13,000,000 for each and every claim to be maintained at all times during the Term;
  - (b) Public liability insurance for an amount of not less than €6,500,000 for each and every claim to be maintained at all times during the Term;
  - (c) Professional indemnity insurance for an amount of not less than €5,000,000 for any one claim to be maintained at all times during the Term and for a period of seven years following the expiration or termination of this Agreement for whatever reason.
- 9.7 At the reasonable request of the Service Provider the Client shall increase the above insurance limits or obtain additional coverage. Prior to the execution of this Agreement and at any time thereafter at the Service Provider's request the Client shall provide the Service Provider with such evidence as the Service Provider will require to verify that the requisite insurance policies are in place in accordance with the terms specified in Clause 9.6..
- 9.8 Any changes to the above policies that may be made from time to time will be

notified to the Service Provider in advance of the implementation of the change.

## **CLIENT LIABILITY AND INDEMNITIES**

- 10.1 The Client shall be solely responsible for any Content (including any technical defects in the Content Transport Stream) whether broadcast by way of pictures, sound, words, text, data or music and shall in particular but without limitation of the foregoing be solely responsible for any defamatory, seditious, blasphemous or obscene matter or any matter which constitutes an injurious falsehood or slander of title or libel or any tort or an infringement of any Intellectual Property Rights or contravention of the provisions of the Official Secrets Act, 1963 or of any statutory enactment or regulation for the time being in force or a criminal offence or contempt of court or breach of parliamentary privilege.
- 10.2 The expiration determination and/or assignment of this Agreement howsoever arising shall not affect the obligations of the Client under this Clause 10 or the Parties under Clause 9 or Clause 19. Nothing contained in this Agreement shall infer or imply that the Service Provider has any responsibility either pursuant to the Broadcasting Acts or under any other statute or law or legislation for the Content.
- 10.3 The Client hereby agrees to indemnify and keep the Service Provider indemnified in respect of all liability, costs, losses, damages and/or any proceedings and/or claims (including the costs and expenses reasonably incurred in dealing with such claims) taken against the Service Provider or any member of the Service Provider's Group in respect of the alleged infringement of any Intellectual Property Rights of any other person, firm or company or in respect of any claim made against the Service Provider or any member of the Service Provider's Group in respect of any defamatory matter, broadcast, or claimed to be broadcast by the Client, its servants, agents or contractors or slander of title, or libel or in respect of any other matter for which the Client is responsible or which arises out of or is connected with the Content and, or, the Content Transport Stream (including those matters set out in Clause 10.1) where any of such matters give rise to a claim against the Service Provider.
- 10.4 In the event of any claim being made against the Service Provider by any third party arising out of any matter contained in or associated with the Content and, or, the Content Transport Stream, the Client shall at the request of the Service Provider provide to the Service Provider copies of any recordings of any such matter contained in or associated with the Content and, or, the Content Transport Stream.
- 10.5 If the Service Provider receives any notice, demand, assessment or other document ("**Third Party Claim**") whereby it appears that the Service Provider may suffer a liability and which may result in the Service Provider having a claim against the Client under the Indemnity in Clause 10.3 above then the Service Provider shall give or procure that notice in writing thereof ("**Indemnity Claim Notice**") is given to the Client as soon as is reasonably practicable.
- 10.6 On reception of an Indemnity Claim Notice from the Service Provider (or on behalf of the Service Provider) the Client hereby agrees and undertakes with

the Service Provider that it will (whilst keeping the Service Provider and the relevant member of the Service Provider's Group fully informed and after consultation with them) deal with the Third Party Claim in the name of the Service Provider (as the case may be) and notify the Service Provider in writing of this fact within 7 days of receipt of the Indemnity Claim Notice and at the sole expense of the Client it will conduct any appeal, dispute or defence of the Third Party Claim and of any incidental negotiations and the Service Provider will give the Client all reasonable co-operation, access and assistance for the purposes of considering and resisting the Third Party Claim provided always that the Client shall make no settlement or compromise of the Third Party Claim which would involve the Service Provider in any way or manner in the settlement or compromise in a public or other way and in particular but without prejudice to the generality of the foregoing which would involve the Service Provider in an apology or other statement of clarification, broadcast or not.

- 10.7 If within 14 days of the receipt by the Client of the Indemnity Claim Notice given by the Service Provider under Clause 10.5 the Client fails to notify the Service Provider in writing pursuant to Clause 10.6 that it is dealing with the Third Party Claim or the Client fails to deal with a claim even after notifying the Service Provider that they will deal with the claim, then the Service Provider shall be free to pay or settle or deal with that claim on their own behalf on such terms as they may in their absolute discretion think fit and without prejudice to their rights and remedies under the indemnity in Clause 10.3 which will apply to any such claim as dealt with by the Service Provider.
- 10.8 The Client shall make payment in full and without any deduction whatever by reason of any set-off, counter-claim, withholding or otherwise on demand in respect of any claim for which the Client has agreed to indemnify the Service Provider hereunder which demand shall so far as the amount is calculable specify the amount recoverable.

## **LICENCES**

- 11.1 The Service Provider shall ensure that all the necessary licences, all other authorisations, permissions, consents, approvals and dispensations which it may require from time to time for the provision of the Services are in place for the Term.
- 11.2 The Client shall obtain and maintain all necessary licences, authorisations, permissions, consents, approvals and dispensations required to avail of the Services and shall promptly notify the Service Provider of any changes to same.

## **AMENDMENTS, VARIATIONS AND RELIANCE ON INSTRUCTIONS**

- 12.1 Subject to Clause 8, any amendment, variation or revision to this Agreement and/or the Services shall not be valid unless carried out in writing and executed by the Authorised Representatives of the Parties.
- 12.2 The Service Provider shall have the right to change the System and/or technical composition of the Content Transport Stream, or to demand a modification, change or addition to any part of the Content Transport Stream or its technical composition or to the frequencies on which it is broadcast, where (a) the Service Provider would, without such a change, be in breach of any regulatory act or requirement or of any authorisation under which it operates and such

change has been imposed by a Competent Authority (b) where a change is required in order to comply with a direction by or requirement of a Competent Authority or (c) where such changes are required in order to facilitate the operation of the System, Services or services provided to third parties. The Service Provider shall give effect to such change request within such timescale as required by law, by a Competent Authority or for technical expediency.

## **SITE ACCESS**

- 13.1 After the Effective Date and provided that the Service Provider is entitled to do so, and further provided 14 days advance notice has been given by the Client to the Service Provider in writing, the Service Provider will facilitate the Client in allowing the Client access to a Site, or Sites, provided the Service Provider is satisfied that the Service Provider's requirements (operational, environmental, health and safety, etc.) on the Site, or Sites, will be adhered to. On any Site visit the Client or any of its employees, servants, representatives or agents, may, at the Service Provider's discretion, be accompanied by a representative of the Service Provider.
- 13.2 The Client hereby agrees that it will not and it will procure that any of its employees, servants, representatives or agents will not interfere with or in any way deal with the System or Equipment used by or the property of the Service Provider or any third party when they or any of them are on the Site, or Sites, and in particular but without prejudice to the generality of the foregoing the Client hereby agrees to indemnify and keep the Service Provider indemnified against any claim, loss, liability, damage, loss to life or injury, loss of transmission by the Service Provider or any member of the Service Provider's Group or any third party or loss of communications facilities or equipment by any third party as a result of the Client's employees, servants, representative or agents interfering with any of the Services and or Equipment used by, or the property of, any third party.
- 13.3 The Client agrees that it shall not, other than in accordance with the terms of this Agreement, enter or attempt to enter either itself or through its employees, servants, agents or representatives the Sites or any of the locations on which the Services, System, or Equipment is for the time being situate.
- 13.4 The Client hereby agrees that it will pay the Service Provider any costs incurred in facilitating Site access. The Service Provider's charges shall be calculated by reference to the Service Provider's reasonable prevailing standard rates of charge.

## **CONFIDENTIALITY**

- 14.1 Each Party undertakes to the others:
  - (a) to keep confidential, and use only for the purposes it was provided, all information concerning the business and affairs of the other Party that it shall have obtained or received as a result of the discussions leading up to or the entering into or performance of this Agreement (the "**Confidential Information**");
  - (b) to exercise the same degree of care and discretion to avoid unauthorised disclosure, publication or dissemination of all Confidential Information as each Party exercises to protect its own

Confidential Information that it does not wish to disclose and will not copy or permit others to copy any information except for a reasonable number of copies necessary to undertake this Agreement all of which information shall be treated in accordance with this standard;

- (c) not without the relevant Party's prior written consent to disclose Confidential Information in whole or in part to any other person save those of its personnel involved in the provision of the Services and who have a need to know the same in order for any Party to comply with this Agreement;
- (d) not during the currency of this Agreement to publish or cause to be published orally or in writing to the public or any section of the public any matter concerning this Agreement or the internal affairs of any Party whether confidential or not without the prior written permission of the relevant Party. Such permission shall not be unreasonably withheld.

14.2 The provisions of this Clause 14 shall survive for five years following the termination of this Agreement.

14.3 The obligations of confidentiality assumed by each Party pursuant to this Agreement shall not apply to:

- (a) Confidential Information of the other Party that comes into the public domain other than by default of the recipient Party; or
- (b) Confidential Information of a Party that is or has already been independently generated by the recipient Party; or
- (c) Confidential Information that is required to be disclosed by law (save that the Party required to disclose it shall, to the extent permitted by law, give the other Party notice of the required disclosure and provide the affected Party with sufficient time and opportunity to dispute with the relevant authority such of the disclosure as the other Party requires);
- (d) is lawfully received by the recipient from a third party on an unrestricted basis; or
- (e) is in the possession of or is known by the recipient Party prior to the date of this Agreement, to the extent that such recipient Party is not bound by any existing obligation or confidentiality in respect of such information to the other Party hereto.

14.4 Subject to Clause 14.5 below, nothing in this Agreement shall prevent a Party disclosing this Agreement or any part of it, to (a) any of its shareholders (b) to its professional advisers.

14.5 The Parties shall use the Confidential Information solely for the purpose(s) for which it was provided and shall not pass Confidential Information to any other business units, departments, subsidiaries, partners or shareholders for whom such Confidential Information could provide a competitive advantage as against the Client or the Service Provider.

## **SCOPE OF AUTHORITY**

- 15.1 The Service Provider shall not be the Client's agent and shall not make any agreements on the Client's behalf or bind the Client to any obligation or in any way act as an agent of the Client.
- 15.2 The Service Provider shall not, without the prior written approval of the Client represent itself as being in any way connected with or interested in the business of the Client.

## **NO PARTNERSHIP OR AGENCY**

- 16.1 Nothing in this Agreement and no action taken by the Parties pursuant to this Agreement shall constitute, or be deemed to constitute, a partnership, association, joint venture or other co-operative entity between any of the Parties.
- 16.2 Nothing in this Agreement and no action taken by the Parties pursuant to this Agreement shall constitute, or be deemed to constitute, any Party the agent of any other Party for any purpose. Neither Party has, pursuant to this Agreement, any authority or power to bind or to contract in the name of the other Party to this Agreement.

## **INTELLECTUAL PROPERTY**

- 17.1 The Client hereby grants to the Service Provider for the Term a non-exclusive royalty free irrevocable licence to broadcast the Content, with the right to sub-licence to sub-contractors approved by the Client, (such approval not to be unreasonably withheld), for the sole purpose of providing the Services. Such licence shall be revocable by the Client provided that the only effective revocation shall be revocation in writing served on the Service Provider at a time which affords the Service Provider the opportunity to prevent distribution and transmission of the Content in question and the Service Provider shall have no liability to the Client in such circumstances.
- 17.2 Nothing in this Agreement shall operate to vest in or transfer to the Client any Intellectual Property Rights, including, but not limited to, broadcasting copyright, under the Copyright and Related Rights Act, 2000 or any equivalent rights anywhere in the world in the Services provided by the Service Provider pursuant to this Agreement or any Intellectual Property Rights in the Content and any such rights shall vest solely in the Service Provider and the Client confirms and acknowledges this.

## **TERMINATION**

- 18.1 Either Party shall be entitled summarily to terminate this Agreement on 30 days notice if the other Party ceases to carry on business in the normal course, commits an act of bankruptcy or is adjudicated bankrupt or enters into liquidation, whether compulsory or voluntary other than for the purposes of amalgamation or reconstruction, or compounds with its creditors generally or has a receiver, examiner, administrator, administrative receiver or liquidator appointed over all or any of its assets or suffers execution or distress or takes or suffers any similar action in consequence of debt or becomes unable to pay its debts as they fall due.

- 18.2 The Service Provider shall be entitled summarily to terminate this Agreement in the circumstances set out in Clause 5.4 or on a Change of Control of the Client.
- 18.3 The expiration or termination of this Agreement hereunder shall not operate so as to affect such of the provisions hereof as are expressed to operate or have effect after termination thereof and shall be without prejudice to any rights or obligations which shall have accrued and be owing prior thereto or which are intended to survive termination of this Agreement.
- 18.4 If the Service Provider terminates this Agreement pursuant to Clause 5.4 or Clause 18.1 or the Client purports to terminate this Agreement in advance of the expiry of the Initial Term the Client shall pay the Termination Sum to the Service Provider. The Termination Sum shall be payable within 20 Business Days of such termination. The Parties agree and acknowledge that any Termination Sum payable hereunder is liquidated damages and a genuine and reasonable pre-estimate of the loss or damage that would be suffered by the Service Provider in the event of early termination by the of the Agreement by or as a result of any act of omission of the Client..
- 18.5 Either Party shall be entitled forthwith on serving a written notice on the other Party to terminate this Agreement on any of the following events occurring:
- (a) if the other Party shall be in persistent material breach of any provision of this Agreement and shall not remedy the material breach or otherwise satisfactorily compensate the complaining Party in respect of such material breach within 30 days of notification in writing of the breach in question;
  - (b) if there is an event of Force Majeure which interrupts provision of the Services, for more than 60 consecutive days.
- 18.6 In the event of termination by the Client pursuant to Clause 18.5(a) of this Agreement, the Client shall be under no obligation to pay the Tariff from the date of termination or in the case of termination in part pursuant to Clause 18.5(b), the Tariff shall be reduced in respect of the Sites in relation to which this Agreement has been terminated. The Client shall be under no obligation to pay the Tariff for the period during which the material breach notified under Clause 18.5(a) persisted or the period of the Force Majeure under Clause 18.5(b). Without prejudice to its rights under this Agreement, including its entitlement to receive Service Credits as applicable, the Client will not be liable to pay the Tariff during any period of suspension of the Services by the Service Provider, including where such suspension arises from Force Majeure, or from any notice from a Competent Authority to suspend broadcasting, or otherwise as a result of the Service Provider's breach of this Agreement or the terms of any licence, regulation or law; or any act or default of the Service Provider its employees, agents or subcontractors.
- 18.7 In the event of termination of this Agreement other than in respect of a termination by the Service Provider pursuant to Clause 18.5, the Service Provider will at the Client's cost and expense provide the Client with all

reasonable assistance in the transition to a new supplier of services.

## **ASSIGNMENT AND SUB-CONTRACTING**

- 19.1 Subject to Clause 19.2, no Party shall assign the benefit or burden of this Agreement without prior written consent of the other Party, such consent shall not be unreasonably withheld.
- 19.2 The Service Provider shall be entitled to assign the benefit or burden of this Agreement to any member of the Service Provider's Group upon written notice to the Client. The Service Provider also shall be entitled to assign the benefit of this Agreement to any financial institution providing finance to the Service Provider.
- 19.3 The Service Provider and the Client reserve the right to sub-contract all or part of any of its obligations (provided that the Client is not entitled to subcontract its payment obligations hereunder) or functions under this Agreement following consultation with the other Party provided that:
- (a) the sub-contractor must be approved in writing in advance by the other Party, such approval not to be unreasonably withheld or delayed;
  - (b) the sub-contractor must be of equal or greater technical expertise than the Service Provider; and
  - (c) the sub-contracting Party shall be liable for the act or omissions of its sub-contractors pursuant to this Agreement.

## **ENTIRE AGREEMENT**

- 20.1 For the purposes of this Clause 20, "**Pre-contractual Statement**" means a draft agreement, undertaking, representation, warranty, promise, assurance or arrangement of any nature whatsoever, whether or not in writing, relating to this Agreement made or given by a Party to this Agreement or any other person at any time prior to the date of this Agreement.
- 20.2 This Agreement constitutes the whole and only agreement between the Parties relating to and the subject matter hereof. Except to the extent repeated in this Agreement, this Agreement supersedes and extinguishes any Pre-contractual Statement relating to the subject matter hereof. Each Party acknowledges that in entering into this Agreement it is not relying upon any Pre-contractual Statement which is not set out in this Agreement.
- 20.3 No Party shall have any right of action against any other Party to this Agreement arising out of or in connection with any Pre-contractual Statement (except in the case of fraud), except to the extent repeated in this Agreement.
- 20.4 In the event of any conflict or ambiguity between the provisions of Clauses 1 to 28 of this Agreement and the Appendices, the provisions of the Appendices shall prevail.

## **DISPUTES AND MEDIATION**

- 21.1 The Parties agree that any dispute which arises concerning the interpretation of this Agreement and/or the performance of the Services and which has not

been resolved by the Authorised Representatives, shall be referred to:

- (a) in the case of the Service Provider, the Executive Director for the time being; and
- (b) in the case of the Client, the ● for the time being;

and such persons shall use all reasonable commercial efforts to resolve any such dispute within fourteen (14) calendar days.

21.2 If the dispute is not resolved by the relevant Parties within the time period referred to above then save in respect of a dispute referable to the Expert under Clause 21.4, the Parties may by agreement in writing attempt to settle all other disputes by mediation in accordance with the rules of the International Centre for Dispute Resolution (ICDR). To initiate the mediation a Party must give notice in writing to the other Party to the dispute requesting mediation and a copy of the request must be sent to ICDR. The mediation will start not later than 21 calendar days after the date of such notice. The commencement of mediation will not prevent the Parties commencing or continuing court proceedings. Unless otherwise agreed between the Parties:

- (a) the mediator will be nominated by ICDR;
- (b) the costs of the mediator shall be borne and discharged equally as between the Parties; and
- (c) the mediation shall be conducted in Dublin, Ireland, at a venue agreed upon by the Parties and the mediator or, failing such agreement, at a venue selected by the mediator in his/her discretion.

21.3 If a dispute or difference arises between the Parties that is technical in nature the Parties may refer such dispute, by agreement in writing between the Parties, for final determination to an Expert (as hereinafter defined).

21.4 The expert for the purposes of this Clause 21 shall be an independent party who has expertise in the area giving rise to the dispute (the “**Expert**”) appointed by agreement by the Parties or, in default of agreement on such appointment, on the application of either Party, by the President for the time being of the Institute of Engineers of Ireland or his duly appointed deputy, who shall carry out his functions in accordance with the following:

- (a) in making a determination, the Expert shall act as an expert and not as an arbitrator and his decision shall (in the absence of manifest error (and the Expert shall give reasons for his determination)) be final and binding on the Parties;
- (b) the Expert shall afford both Parties a reasonable opportunity to be heard and to state their respective cases and to advance arguments or evidence in support of their respective positions; and
- (c) each Party shall bear the costs and expenses of all counsel and other advisers, witnesses and employees retained by it and the costs and expenses of the Expert shall be borne by the Parties in the proportions the Expert may direct or, in the absence of direction, equally.

- 21.5 Nothing in this Agreement shall prevent a Party at any time from:
- (a) seeking (including obtaining or implementing) interlocutory, including interim or other immediate or equivalent relief, from the Irish Courts; or
  - (b) referring the dispute to ComReg in accordance with Regulation 31 and/or Regulation 32 of the Framework Regulations, as appropriate in accordance with any right (if any) either Party may have to request a determination or other appropriate steps for its resolution.
- 21.6 The provision of the Services shall not be delayed or suspended pending the resolution of any dispute other than a dispute in relation to payment of Tariffs.

### **VALIDITY AND WAIVER**

The invalidity in whole or in part of any provision of this Agreement shall not affect the validity of any other provision. A waiver of a breach of any provision of this Agreement shall not constitute a waiver of any subsequent breach of any other provision of this Agreement. Failure by either Party to enforce at any time or from time to time any provision of this Agreement shall not be construed as a waiver thereof.

### **FORCE MAJEURE**

- 23.1 Force Majeure means an exceptional event or circumstance:
- (a) which is beyond the control of the Party claiming Force Majeure;
  - (b) which the Party claiming Force Majeure could not reasonably have provided against before entering into the Agreement;
  - (c) which, having arisen, the Party claiming Force Majeure could not reasonably have avoided or overcome; and
  - (d) which is not substantially attributable to the Party seeking Force Majeure.
- (a) Force Majeure may include, but is not limited to war, hostilities (whether war be declared or not), invasion, act of foreign enemies, epidemic, pandemic, ionising radiation, or contamination by radio-activity from any nuclear fuel, pressure waves caused by aircraft or other aerial devices travelling at sonic or supersonic speeds in an area which is not previously known to be subject to such aircraft flight, rebellion, terrorism, revolution, insurrection, military or usurped power or civil war, riot, civil commotion or disorder, strikes, lockout or labour unrest (except where solely restricted to employees of the Service Provider), bad weather conditions, weather related anomalous propagation or any circumstances beyond the reasonable control of the Party claiming Force Majeure.
- 23.2 If either Party should be directed by the BAI or any other Competent Authority to suspend the Services for any reason, upon receipt of written notification to that effect signed by the Authorised Representative of the relevant Party, the Service Provider shall suspend the Services for the period so notified. Such suspension or cessation shall constitute Force Majeure.

- 23.3 If the Party claiming Force Majeure is prevented or delayed from or in performing any of its obligations under this Agreement by Force Majeure in spite of reasonable endeavours to continue to perform its obligations under this Agreement, then it shall notify the other Party of the circumstances constituting the Force Majeure and of the obligations, performance of which, is thereby delayed or prevented.
- 23.4 In the event of the failure by a Party to perform any of its obligations by reason of a Force Majeure, it shall use reasonable endeavours to recommence performance as soon as reasonably practicable. That Party shall also use reasonable endeavours to mitigate and/or eliminate the consequences of any event of Force Majeure and inform the other Party of the steps which it is taking or proposing to do so.
- 23.5 In the event of a Force Majeure event affecting a Party, the Party so affected shall be excused the performance of the specific obligation(s) affected by the event of Force Majeure for the length of the Force Majeure event only.
- 23.6 During any period during which the Service Provider is excused performance for reason of a Force Majeure, the Tariff shall be reduced by such amount as is equitable paying due regard to the reduced level of the Services being provided and any cost savings in respect of the Service Provider's provision of the Services from which it will benefit during the period of excused performance.

## **COSTS**

Each Party to this Agreement shall pay its own costs of and incidental to this Agreement.

## **COMPLIANCE WITH STATUTE**

The Parties shall comply with all the requirements and/or obligations of any statute, statutory instrument, rule, order, regulations, directive and/or by-law laid down by legislation, a Competent Authority dealing with and relating to the provision of the Services or any other provision of this Agreement.

## **SEVERANCE**

In the event that any provision of this Agreement is declared by any Competent Authority to be void, voidable, illegal or otherwise unenforceable or indications of the same are received by either of the Parties from any relevant authority, the Parties shall amend that provision in such reasonable manner as achieves the intention of the Parties without illegality or it may be severed from this Agreement and the remaining provisions shall remain in full force and effect.

## **NOTICES**

- 27.1 Any notice or other communication whether required or permitted to be given by one Party hereto to the other shall be in writing and shall be deemed to have been duly given if signed or transmitted by or on behalf of a duly authorised officer of the Party giving the notice and:-
- (a) if delivered, at the time of delivery to the addressee or its duly authorised agent;

- (b) if sent by pre-paid post, four days after posting if addressed to the Party to whom such notice is to be given at the address set forth for such Party in this Agreement (or such other address as is from time to time notified to the other Party hereto);
- (c) if transmitted by email, on acknowledgment of receipt by the Party to whom it is transmitted.

27.2 All notices to the Parties under this Agreement shall be in writing and sent to Authorised Persons at the address set out in the preamble above or as amended by the Parties on notice in writing from time to time.

### **GOVERNING LAW AND JURISDICTION**

- 28.1 This Agreement shall be governed by and construed in accordance with the laws of Ireland.
- 28.2 Subject to Clause 21, each of the Parties to this Agreement irrevocably agrees that the courts of Ireland are to have exclusive jurisdiction to settle any dispute arising out of or in connection with this Agreement and, for such purposes, irrevocably submits to the exclusive jurisdiction of such courts. Any proceeding, suit or action arising out of or in connection with this Agreement (“**Proceedings**”) shall therefore be brought in the courts of Ireland.
- 28.3 Each of the Parties to this Agreement irrevocably waives any objection to Proceedings in the courts referred to in Clause 28.2 on the grounds of venue or on the grounds of *forum non conveniens*.

**IN WITNESS** whereof the Parties hereto have entered into this Agreement the day and year first herein written:-

**SIGNED** for and on behalf of  
**RTÉ TRANSMISSION NETWORK DAC**  
by:

Signature: .....  
Name: .....  
Address: .....  
Occupation: .....

*in the presence of:-*

Signature of witness: .....  
Name: .....  
Address: .....  
Occupation: .....

**SIGNED** for and on behalf of  
● by:

Signature: .....  
Name: .....  
Address: .....  
Occupation: .....

*in the presence of:-*

Signature of witness: .....  
Name: .....  
Address: .....  
Occupation: .....

## APPENDIX A

### SERVICE SCHEDULES

## **SERVICE SCHEDULE 101**

### **Digital Terrestrial Television Distribution and Transmission Broadcast Service**

#### **INDEX**

- 1. Scope & Objectives**
- 2. Specific Terms and Conditions**
- 3. Service Delivery Requirements**
- 4. Broadcast System Parameters**
- 5. Signal Interface Points**
- 6. Signal Specification**
- 7. Distribution & Transmission System Operation**
- 8. Supervisory Control And Data Acquisition (SCADA)**
- 9. Coverage**
- 10. Standby Electrical Power**
- 11. Service Availability and Service Credits**
- 12. Sample Reports**
- 13. Reference Documents**
- 14. Abbreviations**

- Table 1**            **List of Sites, Locations and Transmission Site Parameters.**
- Table 2**            **Points Of Contact.**

## 1.0 Scope & Objectives

- 1.1 The provision by the Service Provider 24 hours a day, during each day of each year of the Agreement of a digital terrestrial television distribution and transmission service to the Client in respect of the Client's Multiplexed Transport Stream. Subject to the provisions of Clause 23 (Force Majeure) of the Agreement, the Service Provider shall ensure that the Client's Multiplexed Transport Stream presented at the Signal Interface Points (as defined in Section 5 below) are distributed via the distribution and transmission System as outlined in Table 1. The Service provided by the Service Provider shall be in compliance with the standards and requirements as set out in this Appendix.

## 2.0 Specific Terms and Conditions

### 2.1 Initial Term

The provision of the Service is subject to an Initial Term of 12 years (*subject to Client broadcast licence*). Prior to the expiry of the Initial Term, the Parties may agree to extend the Initial Term by a further period of 5 years. Prior to the expiry of the Term, the Parties may agree to extend the Term for successive terms of five years.

- 2.2 Upon Termination of the Agreement, the Parties agree that a Termination Sum will be payable by the Client as follows:

- (i) in the event the Termination Date is prior to the fifth anniversary of the date of this Agreement, as of the Termination Date, the sum of all future Tariff payments, based upon the most recent Tariff Model as of that date (where the operating charge component of the Tariff will be calculated using the most recent operating charge invoiced to the Client prior to the Termination Date), that would have been payable by the Client from the Termination Date to the fifth anniversary of the date of this Agreement including any Tariff payments due but not yet paid, together with an amount equal to the Tariff payable in the 18 month period immediately preceding the Termination Date; or
- (ii) in the event the Termination Date is on or after the fifth anniversary of the date of this Agreement the Termination Sum shall be calculated as follows:

<i>Termination Date</i>	<i>Termination Sum</i>
On or after fifth anniversary of the Agreement but before the sixth anniversary	100 per cent of the Tariff payments payable in the preceding 18 month period
On or after sixth anniversary of the Agreement but before the seventh anniversary	100 per cent of the Tariff payments payable in the preceding 18 month period
On or after seventh anniversary of the Agreement but before the eighth anniversary	100 per cent of the Tariff payments payable in the preceding 18 month period
On or after eighth anniversary of the Agreement but before the ninth anniversary	100 per cent of the Tariff payments payable in the preceding 18 month period

On or after ninth anniversary of the Agreement but before the tenth anniversary	100 per cent of the Tariff payments payable in the preceding 12 month period
On or after tenth anniversary of the Agreement but before the eleventh anniversary	100 per cent of the Tariff payments payable in the preceding 12 month period
On or after eleventh anniversary of the Agreement but before the twelfth anniversary	100 per cent of the Tariff payments payable in the preceding 12 month period

2.3 The provision of the Service is conditional upon the Client providing Security to the value of the Termination Sum.

### 3.0 Service Delivery Requirements

3.1 The Service Provider shall deliver a service that meets the following minimum service delivery requirements for each Multiplexed Transport Stream:

Service Availability Target at each site:	Operating at, or within, the Upper and Lower Failure Thresholds for 99.8% of the time. Excluding any Non-Ranking Events as specified in Section 11.
Availability measured over:	Each quarterly calendar period.
Normal Operating Power per site:	ERP as defined in Table 1.
Normal Operating Frequencies:	As defined in Table 1.
Upper Failure Threshold:	> Normal Operating Power +1dB.
Lower Failure Threshold:	< Normal Operating Power -3dB.

ERP = Effective Radiated Power.

3.2 The Service Provider shall radiate the nominal Effective Radiated Power (ERP) indicated in Table 1. The ERP shall be delivered utilising a defined antenna pattern that shall ensure that network and international interference are minimised and any International restrictions are complied with in so far as is reasonably possible.

3.3 The Lower Failure Threshold figure triggers the initial change over to any reserve transmitter (where available).

3.4 The use of any reserve facility that is common with any other broadcast customer shall be prioritised on a first come first served basis. The Client may identify a priority for its Multiplexed Transport Streams if it has more than one.

3.5 The Service Provider shall comply with the relevant parts of the ComReg Licence obligations when such obligations having been notified to the Service Provider by the Client.

3.6 The Service Provider shall ensure that the service delivered complies with the engineering performance measures detailed below.

### 3.7 Engineering Performance Measures

The following are measured at the output of the Main Site Transmitters identified in Table 1

Parameter	Operating Limits	Fault Limits	Method of Measurement	Monitoring	See Note
<b>Transport Stream</b>					
Transport stream validity	Valid	Valid	Reference receiver and Transport Stream Analyser	Continuous	B
Transport Stream Errors: Post-RS	N/A	Quasi Error Free (QEF) : <1 uncorrected event per hour	Reference receiver and Transport Stream Analyser	Periodic every 6 months	
SI Integrity	Valid	Valid	Reference receiver and Transport Stream Analyser	Continuous	
Wrong Services	None	None	Reference receiver and Transport Stream Analyser	Continuous	

Transmitter					
Carrier Power Error	±1.0dB	>-3.0dB	Calibrated directional coupler connected to a calibrated power meter	Continuous	C
Centre Frequency Error	<±500Hz	>±500Hz	Frequency counter, or Special COFDM test-set or spectrum analyzer	Periodic every 6 months	D
Amplitude Response (f <sub>c</sub> +/- 3.60 MHz)	±1.4dB (w.r.t. f <sub>c</sub> )	+1.5, -2.0 dB (w.r.t. f <sub>c</sub> )	Spectrum analyzer	Periodic every 6 months	
Amplitude Response (f <sub>c</sub> +/- 3.805 MHz)	<+1.4, -2.5 dB (w.r.t. f <sub>c</sub> )	>+1.5, -4.0 dB (w.r.t. f <sub>c</sub> )	Spectrum analyzer	Periodic every 6 months	
Group Delay Response (f <sub>c</sub> +/- 3.805 MHz)	<±2100ns	>±2100ns	Group Delay test set	Periodic every 6 months	
Out-of-band spurious emissions	In accordance with ComReg specification 07/90b	In accordance with ComReg specification 07/90b	Spectrum analyzer RBW = 3kHz	Periodic every 6 months	E
Radiated COFDM bit error ratio:	N/A	>1 × 10 <sup>-3</sup>	Reference receiver	Continuous	
Modulation Error Ratio MER	>29.5dB	<28dB	MER Analyser	Continuous	F

The following are measured at the output of the Transposers and/or Re-transmitters identified in Table 1

Parameter	Operating Limits	Fault Limits	Method of Measurement	Monitoring	See Note
<b>Transposer or Re-transmitter</b>					
Carrier Power Error	±1.0dB	>-3.0dB	Detected by the transmitter which is calibrated annually	Continuous	
Centre Frequency Error	<±500Hz	>±500Hz	Frequency counter, or Special COFDM test-set or spectrum analyzer	Periodic every 12 months	D
Amplitude Response (fc+/- 3.805 MHz)	<+1.5, -4.0 dB (w.r.t. fc)	>+2, -4.5 dB (w.r.t. fc)	Spectrum analyzer	Periodic every 12 months	
Group Delay Response (fc+/- 3.805 MHz)	<±2100ns	>±2100ns	Group Delay test set from input to output	Periodic every 12 months	
Out-of-band spurious emissions	In accordance with ComReg specification 07/90b	In accordance with ComReg specification 07/90b	Spectrum analyzer RBW = 3kHz	Periodic every 12 months	E
Radiated COFDM bit error ratio:	N/A	$>1 \times 10^{-6}$	Reference receiver	Periodic every 12 months	
Modulation Error Ratio MER	>29.5dB	<25dB	MER Analyser	Periodic every 12 months	F

**The notes below should be read in conjunction with the Tables above.**

- A. If it proves impossible to transmit the Multiplexed Transport Stream with parameters better than or equal to the operating limits, the Service Provider shall continue to transmit at the highest technical standard possible.
- B. A transport stream is valid if it complies with ETR 101 290 with no first priority alarms, is DVB compliant, has correct Programme Association Data, and is decodable by a SAORVIEW Approved Receiver.
- C. Carrier Power is measured on a calibrated precision probe. Continuous monitoring will be via a thermal power meter, which will be periodically calibrated. Both the operating and Fault limits will be continuously monitored. Selection of a reserve transmitter where available will be initiated at the Fault limit. Periodic measurements may be made using a thermal power meter.

- D. When measured by the relevant test set, the frequency error shall be deduced using an external 10MHz reference.
- E. The Service Provider shall comply with the ITU Radio Regulations (2012 Edition) for out of Band Harmonics and Emissions and ComReg specification 07/90b in relation to filtering for adjacent channels.
- F. Loss of noise margin, including effects of phase noise, excessive group delay and inter-modulation products, is measured implicitly by monitoring Modulation Error Ratio (MER).

#### **4.0 Broadcast System Parameters**

- 4.1 The Client will present, or arrange to have presented, the agreed Multiplexed Transport Stream(s) at the Signal Interface Points, from which the Service Provider will accept, distribute and transmit them on the frequencies and from the transmission sites listed in Table 1 attached. The Service Provider shall ensure that the Multiplexed Transport Stream(s) is only transmitted from its sites on frequencies authorised for this purpose.
- 4.2 Subject to Clause 3 (Term) of the Agreement, the Service Provider will transmit from the locations listed in Table 1 in accordance with the roll-out schedule detailed in Appendix C (*Roll Out*).

#### **5.0 Signal Interface Points**

- 5.1 The Client shall present two diverse and separate feeds for each Multiplexed Transport Stream(s) at two Signal Interface Points for distribution to, and transmission from, the transmission sites detailed in Table 1.

“**Multiplexed Transport Stream**” means the electronic form in which the Client’s audio, video and data is supplied to the Signal Interface Point.

The Service Provider has two Signal Interface Points at its premises at Cookstown Court in Tallaght, Dublin 24 and has a further two Signal Interface Points located adjacent to the tower on the RTÉ campus in Donnybrook Dublin 4.

- 5.2 Transposer and Re-transmitter sites will receive their input source signals from one of the main transmission sites, or another Transposer site, or another Re-transmitter site, as per Table 1, and retransmit.

#### **6.0 Signal Specification**

- 6.1 Multiplexed Transport Stream Distributed by the Service Provider.

The Multiplexed Transport Stream for each multiplex presented at the Signal Interface Points shall be:

- Up to a maximum of 24.128 Mbit/s
- Digital Video Broadcast Asynchronous Serial Interface (DVB-ASI)
- MPEG-2 Multiple Programme Transport Stream
- BNC Physical Interface

## 6.2 System Operation Data

In addition to audio, video, data and other services individual to each multiplex, each Multiplexed Transport Stream will include EIT, Electronic Programme Guide, Service Information, Conditional Access and any other operational data required for the interoperation of all Digital Terrestrial Television multiplexes Distributed and Transmitted by the Service Provider.

## 6.3 Multiplexed Transport Stream Transmitted by the Service Provider

The Multiplex Transport Stream will be modulated as follows:

Modulation	64QAM
Coding Rate	2/3
Guard Interval	1/32
Number of Carriers	8k

The total bit rate shall be 24128342 bits per second which is commensurate with the chosen transmission parameters, as per section 7.2. Each Multiplexed Transport Stream will include Electronic Programme Guide, System Information, Conditional Access or any other data required for the interoperation of all Digital Terrestrial Television multiplexes Distributed and Transmitted by the Service Provider. The Client will be responsible for data integrity, service priority within the statistical multiplex and the overall management of Multiplexed Transport Stream payload. It will be a matter for the Client to determine the number and quality of the television and other services to be carried in each Multiplexed Transport Stream.

## 7.0 Distribution & Transmission System Operation

The Clients Multiplexed Transport Stream presented at the Signal Interface Points shall be transported to eleven main transmission sites via a combination of fibre optic cables and microwave radio links and shall be transmitted from those sites.

### 7.1 Distribution

Each Multiplex Transport Stream is multiplexed with other services and distributed to the transmission sites. The Service Provider utilises interconnected equipment at Cookstown Court in Tallaght and at RTÉ in Donnybrook to achieve diverse connectivity to the microwave radio distribution system. An overview is shown in Figure 7.1.1.

**Figure 7.1.1 Distribution multiplexing overview**

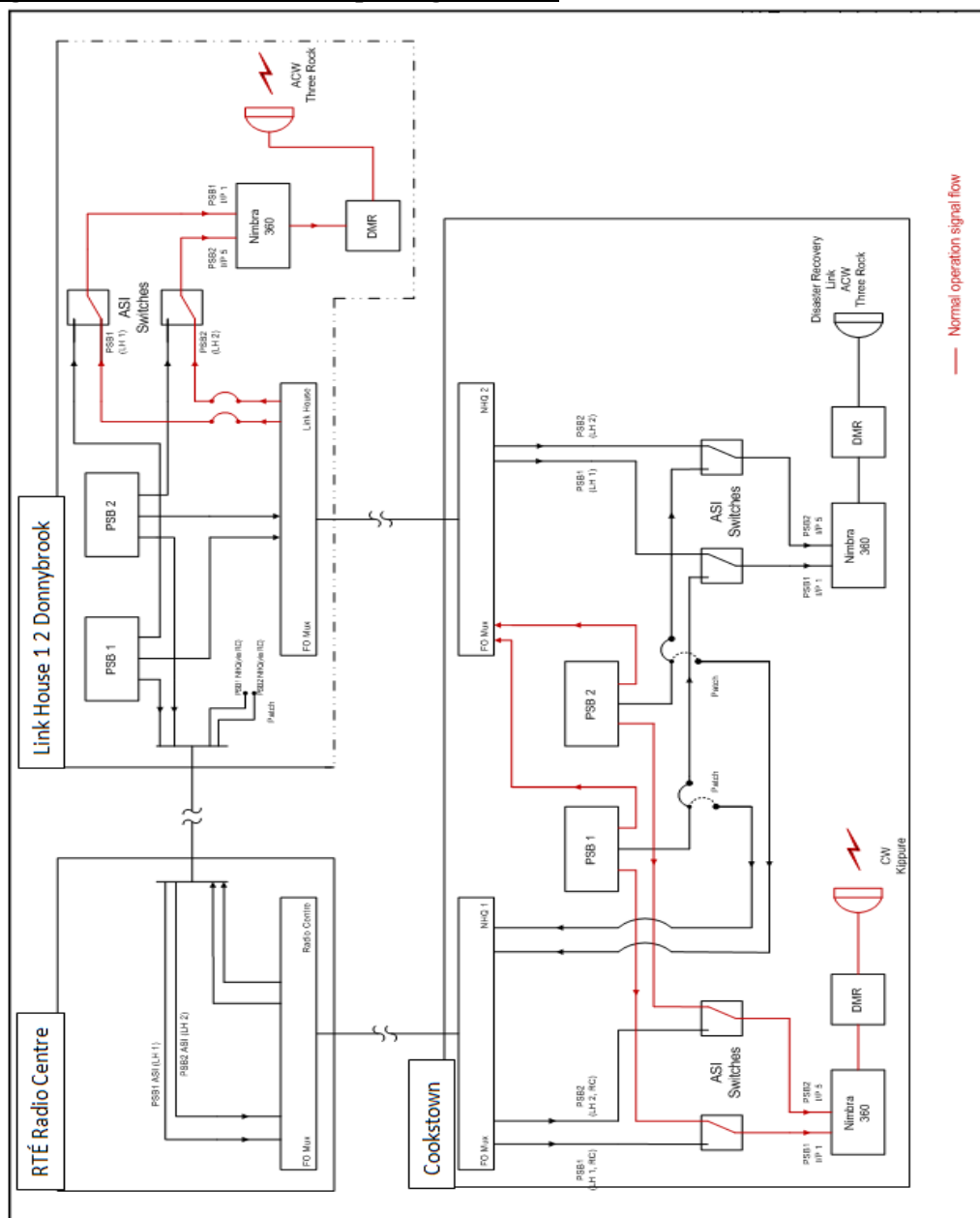

The primary distribution system consists of two STM-1 microwave radio circuits with two radial spurs. An overview of the microwave radio distribution system is shown in Figure 7.1.2. *[Please Note The Service provider is currently in the process of migrating its distribution system to a hybrid fiberoptic/fixed radio link network and this section 7.1 is subject to change.]*

**Figure 7.1.2 Distribution system overview**

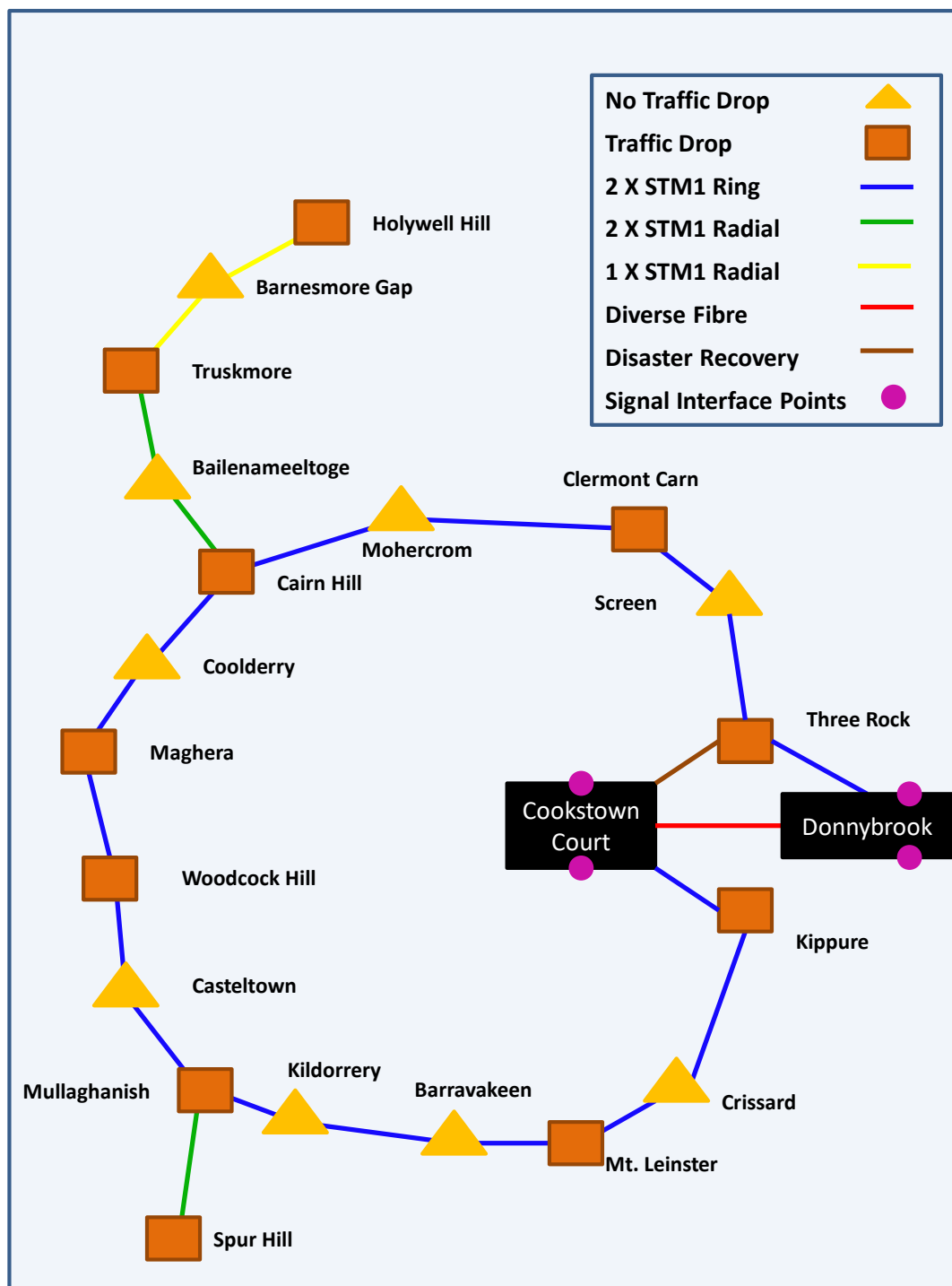

The secondary distribution system to infill transmission sites (transposers and/or re-transmitters) is by reception of a source, off-air, signal from other transmission sites which are then transposed or re-transmitter.

## 7.2 Transmission

At the main transmission sites the Multiplexed Transport Stream is fed to the transmitters which produce an RF signal at the specified power.

None of the transmitter outputs are synchronised with each other; they operate in a Multi-Frequency Network (MFN).

At the main transmission sites each antenna is constructed in two halves and each half has its own feeder cable. The overarching design criterion is that the antenna can facilitate full power into either half of the antenna system.

At the main transmission sites each Multiplexed Transport Stream has its own transmitter. Each transmitter has dual drives and there is an additional transmitter on site which can automatically replace any of the active transmitters if the need arises (N+1 configuration). The Service Provider employs solid state transmitters which have multiple output modules and therefore degrade gracefully in the vast majority of fault situations.

The outputs from the active UHF transmitters are combined and the power split across the two halves of the antenna.

An overview of the arrangement for main sites can be seen in Figure 7.2.1.

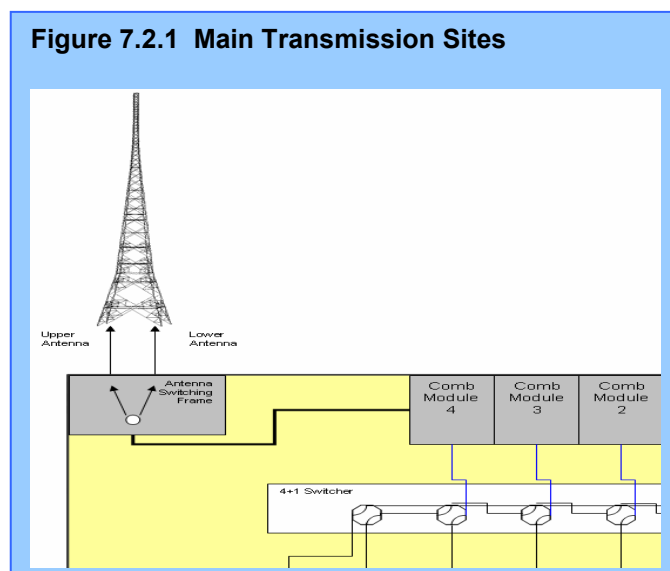

## 7.3 Network Monitoring Centre (NMC)

7.3.1 The Service Provider operates a Network Monitoring Centre (NMC) in which the status and control of all elements of network infrastructure is monitored. The NMC provide a staffed point of contact (contact details in Table 2) through which all enquiries and fault notices and other reports are channelled and logged, during NMC staffed hours. Each week of the year, depending on operational demands, the NMC is staffed during the period 07:00 to 23:00 from Monday to Friday inclusive,

and 08:00 to 22:00 on Saturday and Sunday. Outside of NMC staffed hours calls and enquiries are registered or recorded electronically for attention next day.

- 7.3.2 All relevant enquiries, fault notices, or other reports conveyed by telephone, email, or otherwise, to the Service Provider are logged on a fault database.
- 7.3.3 Every fault incident identified by, or reported to, the NMC, including those from the Service Provider staff, are given a unique call reference number and the logging process captures all the relevant details pertinent to the call. The logging system is used as the basis for tracking faults to resolution, and generation of reports.

Details of the logging shall include the following:

- Name of the caller (if applicable)
- Date and time
- Transmission site location (if known)
- Contact number (if applicable)
- Service affected
- Description of the nature of the fault
- Fault category level.

- 7.3.4 All relevant alarms raised by the Service Provider's SCADA system (Supervisory Control and Data Acquisition) are logged.
- 7.3.5 The NMC processes all calls through to a successful conclusion and ensure that the Client will be able to obtain updates on all incidents from a single point of contact.

#### 7.4 Fault Incidents

- 7.4.1 During the staffed hours of the NMC. When the NMC receives information on a fault incident it is logged. Where the fault is with the System, a fault response as per Section 7.3 is initiated. Where the fault incident is not with the System, but is within the responsibility of the Client, the NMC will contact the Client as soon as possible by email and/or telephone as per Section 7.3.
- 7.4.2 When received, each fault incident shall be assessed and appointed a level of severity. In the event that the Client and the NMC / on-call engineer cannot agree which severity level should be allocated to the fault, the matter will be referred to each representative's immediate superior for determination. During any disagreement, between the Client and the Service Provider, on the severity level to be appointed the more severe, higher level, will be used.
- 7.4.3 Outside the staffed hours of the NMC the scheduled on-call engineer will be alerted to all relevant alarms raised by the Service Provider's SCADA / automated alarm system. The relevant information will be communicated to the NMC the following morning for processing as per Section 7.3.

7.4.4 The following list describes the fault level categories.

Category	Disruption
Level 1 >= Main Transmitter Site Faults	<ol style="list-style-type: none"> <li>1. Total loss of, or a reduction in Power greater than Lower Failure Threshold in, the output of any active transmitter.</li> <li>2. Total loss of or degradation below the MER Fault Limit on any active transmitter.</li> <li>3. Disruption to, or loss of, ancillary data services such as EPG, SI and CA (as applicable) normally carried on any multiplex at a main transmission site.</li> <li>4. Total failure of the primary distribution system (Microwave Radio Links system) at the site or location.</li> </ol>
Level 2 >= Priority Transposer or Priority Re-transmitter Site Faults	<ol style="list-style-type: none"> <li>1. Total loss of, or a reduction in Power greater than Lower Failure Threshold in, the output of any active priority transposer or priority re-transmitter.</li> <li>2. Total loss of or degradation below the thresholds of the MER on any active transmitter at a priority transposer or priority re-transmitter site.</li> <li>3. Disruption to, or loss of, ancillary data services such as EPG, SI and CA (as applicable) normally carried on any multiplex at a priority transposer or priority re-transmitter.</li> <li>4. Total failure of the secondary distribution system (Rebroadcast) at a priority transposer or priority re-transmitter site.</li> </ol>
Level 3 >= Transposer or Re-transmitter Site Faults	<ol style="list-style-type: none"> <li>1. Total loss of, or a reduction in Power greater than Lower Failure Threshold in, the output of any active transposer or re-transmitter.</li> <li>2. Total loss of or degradation below the thresholds of the MER on any active transmitter at a transposer or re-transmitter site.</li> <li>3. Disruption to, or loss of, ancillary data services such as EPG, SI and CA (as applicable) normally carried on any multiplex at a transposer or re-transmitter.</li> <li>4. Total failure of the secondary distribution system (Rebroadcast) at a transposer or re-transmitter site.</li> </ol>
Level 4	Any other fault

7.4.5 Subject to Clause 3 (Term), the Client may from time to time require the Service Provider to investigate documented generalised complaints concerning the Client's coverage/signal strength in areas where adequate coverage is predicted by the Service Provider.

7.4.5.1 The Service Provider will be entitled to levy additional fees for such work, where such work is not covered by a pre-existing obligation under this Agreement and where the investigation proves that coverage/signal strength is as predicted. The Service Provider will conduct two investigations (maximum of three man days each) per Multiplex Transport Stream per year without levying additional fees.

7.4.5.2 The Service Provider will not be entitled to levy additional fees for such work, where such work is covered by a pre-existing obligation under this Agreement and where the investigation proves that coverage/signal strength is not as predicted. The Client may be entitled to a Service Credit under Section 11 in this situation.

## 7.5 Fault Response

- 7.5.1 During the staffed hours of the NMC. The NMC shall undertake an initial investigation and where appropriate ask the engineer(s) at work or on-call to verify the existence of a fault. Once a fault has been identified, it is addressed and processed in line with the procedure outlined in Section 7.3. Outside of the engineer's normal working hours, if necessary the NMC will alert the on-call engineer(s) to attend the fault(s).
- 7.5.2 Outside the staffed hours of the NMC. The scheduled on-call engineer shall undertake an initial investigation and verify the existence of a fault. Once a fault has been identified, it is addressed and the relevant information communicated to the NMC the following morning for processing as per Section 7.3.
- 7.5.3 In the event that any level fault cannot be resolved by remote control a Service Provider engineer (subject to Sub Sections 7.5.5, 7.5.6, 7.5.7 and 7.5.8 below) shall attend the site of the fault within the "Maximum Response Time" as detailed in Table 1.
- 7.5.4 For the purposes of this Agreement, "Maximum Response Time" shall mean the time between the Service Provider first becoming aware of a Level 1, Level 2 or Level 3 fault at a site, either through its own monitoring or by a confirmed report from the Client and the arrival at the site of suitably trained and skilled personnel to investigate and seek to remedy such fault, or the resolution of the fault by other means. This is the maximum response time and the Service Provider would expect to, and endeavour to, attend all faults substantially inside this maximum.
- 7.5.5 For Level 1 faults, when site attendance is required, and when it is not possible for an engineer to attend site where the fault is located at or before 23:30 from Monday to Sunday an engineer will attend the following day, at or before 06:30 on Monday to Friday and at or before 08:00 on Saturday and Sunday.
- 7.5.6 For Level 2 faults, when site attendance is required, when it is not possible for an engineer to attend site where the fault is located at or before 23:30 from Monday to Sunday an engineer will attend the following day, at or before 08:00 Monday to Sunday.
- 7.5.7 For Level 3 faults, when site attendance is required, during the periods 08:00 to 18:45 on each of the seven days of each week of the year, when it is not possible for an engineer to attend the site where the fault is located at or before 18:45 an engineer will attend at or before 08:00 the following day.
- 7.5.8 Level 4 faults will be addressed during normal working hours, 08:00 to 18:45 Monday to Friday.
- 7.5.9 During the staffed hours of the NMC. The NMC shall notify the Client by email of all fault incidents and keep the Client updated as in accordance with the following:

<b>Category</b>	<b>Time interval</b>
Level 1	Before 30 minutes and then every 3 hours.
Level 2	Before 30 minutes and then every 6 hours.
Level 3	Before 7 days and them Monthly by report.
Level 4	Monthly by report

7.5.10 The Maximum Response Times and Maximum Site Attendance Times given in Table 1 attached are for the first callout in a geographic engineering area and subject to fair weather. For multiple callouts in an engineering area, when the first callout is completed the engineer will then respond to further callouts.

## 7.6 Escalation Process

7.6.1 The Service Provider shall respond to faults in accordance with the time limits described in this Section 7.5. In the event that resolution of a fault does not occur as outlined in Section 7.5, it is agreed that the Client may escalate the fault response process according to the following timetable:

Category	Client	Service Provider	Time interval
Level 1	?????	NMC Engineer	After 1 hour
	& ???????	& Operations Manager	After 3 hours
	& ????????????	& Executive Director	After 6 hours
Level 2	????????????	NMC Engineer	After 2 hours
	& ????????????	& Operations Manager	After 4 hours
	& ????????????	& Executive Director	After 8 hours
Level 3	????????????	NMC Engineer	After 5 days
	& ????????????	& Operations Manager	After 8 days
	& ????????????	& Executive Director	After 14 days
Full contact details are included as Table 2			

7.6.2 Escalation will be deemed to occur where the Client considers that there has been a failure to provide the agreed level of service. The Service Provider will in these circumstances empower suitable personnel with a level of authority, control and resources to ensure the Service Provider meets the agreed level of service.

## 7.7 Reporting

7.7.1 The NMC manager shall, on a monthly basis, make available on the Service Providers website an overview performance report for each Multiplexed Transport Stream. Report sample templates are attached in section 12 of this Appendix A. The report will incorporate a table showing the actual performance for the month for each metric, and the target performance for that metric. The table will be followed by text briefly explaining the reason for any shortfall against target and/or any missing metrics.

7.7.2 In the case of Level 1 and 2 faults, upon request from the Client to the NMC, a report on the individual event will be promptly prepared and issued by the NMC manager.

7.7.3 The Client and/or the Service Provider may request a formal review meeting in the event that one or more of the System service commitments in this Agreement are not met.

## 7.8 Routine Meetings

7.8.1 A general review meeting will be held every three months between Authorised Representatives from the Client and the Service Provider (Authorised Representatives will be identified by the Client and the Service Provider in Table 2). The function of these meetings will be to:

- To review the System performance in the previous period.
- To discuss and resolve any outstanding issues arising.
- To address any upcoming requirements.
- Update personnel/contact changes or other changes in Appendixes A, B and C.

### 7.8.2 Documentation – records.

7.8.2.1 The Service Provider shall make sure that it keeps accurate, complete and up to date records for the term of this Agreement and for 3 years after its expiry or termination.

7.8.2.2 The Service Provider shall retain the information required to evidence compliance with its obligations under this Agreement.

## 7.9 Maintenance

Routine preventative maintenance will be undertaken primarily during normal working hours. This will particularly be the case for antenna maintenance for Health & Safety reasons. All reasonable efforts will be made to ensure minimal interruptions to the distribution and transmission service and the Client, and/or any Authorised Representative nominated by the Client, will be given 5 days' notice of any work which may have a direct impact on the distribution or transmission of the Multiplexed Transport Stream to viewers. Notification of service effecting outages or power reductions (to a level below the Lower Failure Threshold) shall be issued with a minimum notice period of 5 calendar days using the Outage Notification Form (sample in section 12.2). The works as described in Outage Notification Form shall proceed as outlined unless commented upon by the Client, and/or any Authorised Representative nominated by the Client, within 2 calendar days of the Outage Notification Form being issued.

Masts, antenna, combiners and other common equipment are used for more than one client. Where agreement cannot be reached with all clients in relation to power reductions (to a level below the Lower Failure Threshold) or outages the Service Provider reserves the right for the Service Provider Executive Director to adjudicate.

Maintenance on the distribution system will be managed to ensure that, where it is necessary to take a distribution feed out of service, the alternative feed is available and put into service.

On sites, where there is a reserve “+1” transmitter (N+1) available, this will be put into service during periods when maintenance is being carried out on a primary transmitter. Sites having the reserve “+1” transmitter are shown in Table 1.

For antenna system maintenance, where possible, maintenance will be undertaken by switching to a reserve antenna, where available, or to “half stack” operation. Where this is not possible, interruptions to the transmission will be kept to a minimum and agreed in advance.

The Service Provider shall maintain the Service and associated equipment as necessary to maintain the availability outlined in Section 3 of this Appendix A.

## **8.0 Supervisory Control And Data Acquisition (SCADA)**

8.1 In addition to the monitoring of the integrity of the Multiplexed Transport Stream at the Signal Interface Points and transmitter outputs as outlined in Section 3 and 7 of this Appendix A, the Service Provider operates a SCADA system and this is used to control and monitor the System performance. There are two levels of interface with the transmission sites:

8.1.1 Monitoring. The SCADA system monitors a number of preset parameters on the transmission equipment and at the Signal Interface Points and raises, reminders, alarms, notifications, etc.

8.1.2 Control and Monitoring: As 8.1.1 but also allows Engineers and/or the NMC to undertake a number of tasks remote from the transmission site such as switching, resetting, parameter adjustments, etc.

8.2 Table 1 attached identify the SCADA service available at each transmission site.

## **9.0 Coverage**

9.1 Coverage is not guaranteed. Section 11 below indicates the percentage of population covered from each transmission site. The coverage figures are generated using ATDI coverage modelling software input with the best available information.

Site Information:	Location, Height, etc.
System Parameters:	ERP, Antenna Patterns, etc.
Landscape:	Geographical, Topological, Population, Clutter, etc.

## **10.0 Standby Electrical Power**

10.1 All sites with backup generators are identified in Table 1. These sites are fitted with generators that automatically start-up and provide electrical power in the event that the electrical mains fail. A short interruption to services is experienced at mains failure and mains restore to facilitate source switching.

10.2 As a minimum, each generator shall have sufficient fuel capacity available on site to run continuously for a period of three days.

## **11.0 Service Availability and Service Credits**

### **11.1 Introduction**

The Service is designed, installed and operated to provide viewers/listeners, the population, with the highest availability that can be cost-effectively, and efficiently, obtained. Delivering the Client's Content Transport Stream to the population is the purpose of the Service and therefore Service Availability is measured in terms of, and directly linked to, the population covered by each Site. Similarly Service Credits are also linked to each Site and the population it covers.

### **11.2 Service Availability Target**

11.2.1 The Service Availability Target for each Site is that it operates at, or within, the Upper and Lower Failure Thresholds for 99.8% of the time, as specified in Appendix A, excluding Non-Ranking Events, as specified in Section 11.3 below.

### 11.3 Non-Ranking Events

The following Non-Ranking Events are necessary for the operation and maintenance of the Service, or are outside the Service Provider's reasonable control:-

- 11.3.1 A failure or interruption resulting from the Client's, and/or any Authorised Representative nominated by the Client, refusal to permit such work on any Equipment as the Service Provider reasonably regards as essential;
- 11.3.2 Where resulting from the Service Provider's due compliance with safe working practices stipulated by a Competent Authority or any other health, safety, environmental or other law or generally recognised protocol or standard (whether or not having the force of law);
- 11.3.3 Impairment of the quality of the Multiplex Transport Stream transmitted directly to the viewer due to anomalous propagation conditions;
- 11.3.4 Any fault requiring mast ascent during the hours of darkness or severe inclement weather where, in reasonable judgement of the Service Provider, a potential safety hazard exists;
- 11.3.5 Any breach of this Agreement by the Client, and/or any Authorised Representative nominated by the Client;
- 11.3.6 Any interruption (other than as a result of a breach by the Service Provider) as a result of:
  - 11.3.6.1 The Service Provider complying with a direction from any Competent Authority under the Licences, or from any court of competent jurisdiction requiring the Service Provider or Client, and/or any Authorised Representative nominated by the Client, to cease or suspend transmission, or;
  - 11.3.6.2 The Client, and/or any Authorised Representative nominated by the Client, complying with a direction from any Competent Authority to suspend broadcasting;
- 11.3.7 Any interruption as a result of an engineering test transmission made at the request of the Client, and/or any Authorised Representative nominated by the Client, where the potential effects of the test have been previously discussed by the Client, and/or any Authorised Representative nominated by the Client, and the Service Provider;
- 11.3.8 Any fault requiring attendance at a Site during any period where such attendance is not permitted or is otherwise prevented as a consequence of a security alert or any other Force Majeure event or where the Service Provider is not allowed full and immediate access;
- 11.3.9 Any maintenance work undertaken by the Service Provider pursuant to Section 7;
- 11.3.10 Failure by the Client, and/or any Authorised Representative nominated by the Client, to deliver a valid signal as per Section 6;
- 11.3.11 Any Force Majeure event as contemplated by Clause 23 of the Agreement;
- 11.3.12 A reduction in nominal ERP to a level not below the Lower Failure Threshold for operational or maintenance works.
- 11.3.13 An outage or reduction in nominal ERP to a level below the Lower Failure Threshold where the Client, and/or any Authorised Representative nominated by the Client, is

given prior notice and the Client, and/or any Authorised Representative nominated by the Client, do not raise an objection;

- 11.3.14 Interruptions to the System for up to 60 seconds;
- 11.3.15 Electrical supply failures excepting sites where backup generation is present as per Table 1 of this Appendix A;
- 11.3.16 Interruptions to the primary or secondary distribution systems as a result of anomalous propagation or interference effects, including obstructions, which are outside the Service Provider's reasonable control. The Service Provider will work with planners, developers, County Councils and any other relevant authority to monitor the possibility of obstructions occurring and will notify the Client upon becoming aware of the possibility of an obstruction;
- 11.3.17 Any interruption resulting from defects or failures in the equipment or services provided or operated by, or on behalf of, the Client, and/or any Authorised Representative nominated by the Client, (other than equipment which the Service Provider is required to operate and maintain under this specific Agreement);
- 11.3.18 The Service Provider undertaking any other major works, such as a mast or antenna system replacement, where the outages and / or power reductions are necessary and have been requested and agreed in advance by the Client, and/or any Authorised Representative nominated by the Client.
- 11.3.19 Any service or power reduction undertaken as specified in Clause 5.4 of the Agreement.

#### 11.4 Service Credits

- 11.4.1 At the end of each calendar quarter the Service Provider shall calculate for each Site the total amount of time, if any, that the Service did not meet the Service Availability Target, as specified in Section 3 of this Appendix A.
- 11.4.2 When the actual time of service availability over the calendar quarter is less than the Service Availability Target the following formula shall be applied to calculate the Service Credit that is Payable to the Client:

Service Credit Payable = C x P x D

where:

- C = the per minute Charge/Tariff for the Service(s) at all Sites for the period;
- P = the weighted population coverage percentage for each Site (including any dependants) as set out in the table below. Colum labelled 'Weighted % for Service Credit calculations';
- D = the number of minutes that the Site was below the Service Availability Target in the quarter.

Example: a multiplex service at Kippure has operated outside of the failure thresholds, and below the Service Availability Target, for a period of 45 minutes;

The Service Credits will therefore be based on the following:

- C = €11.42 (Per minute based on a national multiplex example tariff of €6.0m. €6m / minutes in year).
- P = 17.665% (Kippure based on table below).
- D = 45 (minutes)

$$\text{Kippure Service Credit Payable} = C \times P \times D = 11.42 \times 0.17665 \times 45$$

$$\text{Sub Total} = \text{€}90.78$$

Kippure has a RBR dependant Laragh.

$$C = \text{€}11.42 \quad (\text{Per minute based on a national multiplex example tariff of } \text{€}6.0\text{m. } \text{€}6\text{m} / \text{minutes in year}).$$

$$P = 0.02\% \quad (\text{Laragh based on table below}).$$

$$D = 45 \quad (\text{minutes})$$

$$\text{Laragh Service Credit Payable} = C \times P \times D = 11.42 \times 0.0002 \times 45$$

$$\text{Sub Total} = \text{€}0.10$$

$$\text{TOTAL} = \text{€}90.88$$

- 11.4.2.1 For the avoidance of doubt, the amount used for C in the above formula shall be from the Tariff Model for the year in which the quarter falls.
- 11.4.2.2 The Service Provider shall notify the Customer of the period, nature and timing of all faults at each Site.

SITES		COUNTY	Population Covered % / Best Server	Weighted % for Service Credit
1	Cairn Hill	Longford	5.750	5.852
2	Clermont Carn	Louth	6.180	6.289
3	Kippure	Wicklow	16.900	17.199
4	Maghera	Clare	8.060	8.203
5	Mt Leinster	Carlow	6.550	6.666
6	Mullaghanish	Cork	5.690	5.791
7	Spur Hill	Cork	4.090	4.162
8	Three Rock	Dublin	15.840	16.120
9	Truskmore	Sligo	4.450	4.529
10	Castlebar	Mayo	1.930	1.964
11	Clonmel	Waterford	0.620	0.631
12	Cnoc an Or	Kerry	1.210	1.231
13	Crosshaven	Cork	0.710	0.723
14	Dungarvan	Waterford	1.000	1.018
15	Gallows Hill	Waterford	1.000	1.018
16	Greystones	Wicklow	0.540	0.550
17	Holywell Hill	Donegal	0.920	0.936
18	Kilduff	Tipperary	2.690	2.738
19	Knockmoyle	Kerry	0.880	0.896
20	Letterkenny	Donegal	0.620	0.631
21	Monaghan	Monaghan	0.530	0.539
22	Suir Valley	Kilkenny	0.720	0.733
23	Woodcock Hill	Clare	3.080	3.135
24	Achill	Mayo	0.330	0.336
25	Aranmore	Donegal	0.420	0.427
26	Arklow UDC	Wicklow	0.330	0.336
27	Ballina	Tipperary	0.120	0.122
28	Ballybofey	Donegal	0.210	0.214
29	Bandon	Cork	0.150	0.153
30	Bantry	Cork	0.180	0.183
31	Cahir	Tipperary	0.120	0.122
32	Casla	Galway	0.240	0.244
33	Castletownbere	Cork	0.260	0.265
34	Clifden	Galway	0.290	0.295
35	Clonakilty	Cork	0.120	0.122
36	Clonmany	Donegal	0.030	0.031
37	Collins Barracks	Cork	0.260	0.265
38	Dingle	Kerry	0.100	0.102
39	Dooncarton	Mayo	0.100	0.102
40	Drimoleague	Cork	0.110	0.112
41	Drogheda	Louth	0.390	0.397
42	Ennistymon	Clare	0.050	0.051
43	Fanad	Donegal	0.500	0.509
44	Fermoy	Cork	0.220	0.224
45	Ferrypoint	Waterford	0.150	0.153
46	Forth Mountain	Wexford	0.470	0.478
47	Glanmire	Cork	0.190	0.193
48	Glencolumcille	Donegal	0.030	0.031
49	Glenties	Donegal	0.080	0.081
50	Gorey	Wexford	0.180	0.183
51	Greenore	Louth	0.070	0.071
52	Kilkeaveragh	Kerry	0.270	0.275
53	Kilmacthomas	Waterford	0.030	0.031
54	Kinsale	Cork	0.090	0.092
55	Laragh	Wicklow	0.020	0.020
56	Leap	Cork	0.030	0.031
57	Maamclassach	Kerry	0.050	0.051
58	Magheraroarty	Donegal	0.160	0.163
59	Malin	Donegal	0.230	0.234
60	Mitchelstown	Limerick	0.370	0.377
61	Moville	Donegal	0.210	0.214
62	Mt. Gabriel	Cork	0.310	0.315
63	Rosscarbery	Cork	0.040	0.041
64	Timoleague	Cork	0.030	0.031
65	Tonabrocky	Galway	0.440	0.448
66	Wicklow	Wicklow	0.320	0.326
		<b>Total % =</b>	<b>98.260</b>	<b>100.000</b>

**12.0 Sample Reports**

12.1 Sample Outage Report:



**Transmission Outage Report**

**Reference Number:**

**Date:**

**Service(s):**

**Transmission Site(s):**

**Time / Duration of Outage:**

**Report Compiled By:**

**Fault / Outage Summary:**

**Notifications:**

**Details Of Cause & Remedial Actions:**

12.2 Sample Outage Notification Form



**Transmission Outage Notification Form**

**Reference Number:**

**Date:**

**Service(s):**

**Transmission Site(s):**

**Time / Duration of Outage:**

**Details:**

## 12.3 Sample Availability Report

### Monthly Service Availability Figures (Including Electricity Supply Outages)

2009		Jan	Feb	Mar	Apr	May	Jun	Jul	Aug	Sep	Oct	Nov	Dec	Year
ATT	RTÉ One	99.9924	99.9999	99.9999	99.9999	99.9999	99.9999	99.9999	99.9999	99.9999	99.9999	99.9999	99.9999	99.9993
	RTÉ Two	99.9999	99.9916	99.9999	99.9999	99.9999	99.9999	99.9999	99.9999	99.9999	99.9999	99.9999	99.9999	99.9992
	TV3	99.9999	99.9999	99.9841	99.9999	99.9999	99.9999	99.9999	99.9999	99.9999	99.9999	99.9999	99.9999	99.9986
	TG4	99.9999	99.9999	99.9999	99.3284	99.9999	99.9999	99.9999	99.9999	99.9999	99.9999	99.9999	99.9999	99.9439
DTT	Mux 1				99.9999	99.9999	99.2358	99.9999	99.9999	99.9999	99.9999	99.9999	99.9999	99.9150
	Mux 2				99.9999	99.9999	99.9999	99.8654	99.9999	99.9999	99.9999	99.9999	99.9999	99.9850
	Mux 3				99.9999	99.9999	99.9999	99.9999	99.9756	99.9999	99.9999	99.9999	99.9999	99.9972
	Mux 4				99.9999	99.9999	99.9999	99.9999	99.9999	99.9962	99.9999	99.9999	99.9999	99.9995
Radio	RTÉ Radio 1	99.9999	99.9999	99.9999	99.9999	99.9999	99.9999	99.9999	99.9999	99.9653	99.9999	99.9999	99.9999	99.9970
	RTÉ 2FM	99.9999	99.9999	99.9999	99.9999	99.9999	99.9999	99.9999	99.9999	99.9999	99.9423	99.9999	99.9999	99.9951
	RTÉ RnaG	99.9999	99.9999	99.9999	99.9999	99.9999	99.9999	99.9999	99.9999	99.9999	99.9999	99.8642	99.9999	99.9886
	RTÉ Lyric	99.9999	99.9999	99.9999	99.9999	99.9999	99.9999	99.9999	99.9999	99.9999	99.9999	99.9999	99.9756	99.9979
	Today FM	99.9999	99.9999	99.9999	99.9999	99.9999	99.9999	99.9999	99.9999	99.9999	99.9999	99.9999	99.9782	99.9981

### Monthly Service Availability Figures (Excluding Electricity Supply Outages)

2009		Jan	Feb	Mar	Apr	May	Jun	Jul	Aug	Sep	Oct	Nov	Dec	Year
ATT	RTÉ One	99.9924	99.9999	99.9999	99.9999	99.9999	99.9999	99.9999	99.9999	99.9999	99.9999	99.9999	99.9999	99.9993
	RTÉ Two	99.9999	99.9916	99.9999	99.9999	99.9999	99.9999	99.9999	99.9999	99.9999	99.9999	99.9999	99.9999	99.9992
	TV3	99.9999	99.9999	99.9841	99.9999	99.9999	99.9999	99.9999	99.9999	99.9999	99.9999	99.9999	99.9999	99.9986
	TG4	99.9999	99.9999	99.9999	99.3284	99.9999	99.9999	99.9999	99.9999	99.9999	99.9999	99.9999	99.9999	99.9439
DTT	Mux 1				99.9999	99.9999	99.2358	99.9999	99.9999	99.9999	99.9999	99.9999	99.9999	99.9150
	Mux 2				99.9999	99.9999	99.9999	99.8654	99.9999	99.9999	99.9999	99.9999	99.9999	99.9850
	Mux 3				99.9999	99.9999	99.9999	99.9999	99.9756	99.9999	99.9999	99.9999	99.9999	99.9972
	Mux 4				99.9999	99.9999	99.9999	99.9999	99.9999	99.9962	99.9999	99.9999	99.9999	99.9995
Radio	RTÉ Radio 1	99.9999	99.9999	99.9999	99.9999	99.9999	99.9999	99.9999	99.9999	99.9653	99.9999	99.9999	99.9999	99.9970
	RTÉ 2FM	99.9999	99.9999	99.9999	99.9999	99.9999	99.9999	99.9999	99.9999	99.9999	99.9423	99.9999	99.9999	99.9951
	RTÉ RnaG	99.9999	99.9999	99.9999	99.9999	99.9999	99.9999	99.9999	99.9999	99.9999	99.9999	99.8642	99.9999	99.9886
	RTÉ Lyric	99.9999	99.9999	99.9999	99.9999	99.9999	99.9999	99.9999	99.9999	99.9999	99.9999	99.9999	99.9756	99.9979
	Today FM	99.9999	99.9999	99.9999	99.9999	99.9999	99.9999	99.9999	99.9999	99.9999	99.9999	99.9999	99.9782	99.9981

### 13.0 Reference Documents

EN 300 744 Digital Video Broadcasting (DVB); Framing structure, channel coding and modulation for digital terrestrial television

ETR 101 290 Digital Video Broadcasting (DVB); Measurement guidelines for DVB systems

### 14.0 Abbreviations

ATDI	Advanced Topographic Development & Images Limited
ASI	Asynchronous Serial Interface
BAI	Broadcasting Authority of Ireland
CA	Conditional Access
COFDM	Coded Orthogonal Frequency-Division Multiplexing
DTT	Digital Terrestrial Television
DVB	Digital Video Broadcasting
EPG	Electronic Programme Guide
MER	Modulation Error Ratio
MFN	Multiple Frequency Network
MHEG	Multimedia and Hypermedia Experts Group
MPEG	Moving Picture Experts Group
NMC	Network Monitoring Centre
N+1	Backup Transmitter / Transposer System
Post-RS	Post Reed Solomon
PSI	Program Specific Information
QAM	Quadrature amplitude modulation - a modulation scheme
QEF	Quasi Error Free
SCADA	Supervisory Control and Data Acquisition
SI	Service Information
SFN	Single Frequency Network
STM-1	Synchronous Transport Module - a microwave radio circuit
UHF	Ultra High Frequency



## TABLE 2 - Points of Contact

### Fault Response

Service Providers Network Monitoring Centre (NMC)

Tel 1: 01 208 2259  
 Tel 2: 01 208 2685  
 Mob: 087 2423310  
 E-mail: nmc@2rn.ie

### Escalation Process

#### Service Provider

NMC Manager: David Mathews      Tel: 01 208 3095  
 Mob: 087 2940883  
 E-mail: dave.matthews@2rn.ie

Operations Manager: Ronan Dempsey  
 Mob: 087 9853655  
 E-mail: ronan.dempsey@@2rn.ie

Executive Director: Mick Kehoe      Tel: 01 208 2249  
 Mob: 086 813 5979  
 E-mail: mick.kehoe@2rn.ie

#### Client

Head of Transmission:      Tel:  
 E-mail:

Head of Operations:      Tel:  
 E-mail:

Managing Director TV:      Tel:  
 E-mail:

### Routine Meetings

Client Representative:      Name  
 Tel:  
 Mob:  
 E-mail:

Service Provider Representative:      Name: John Clarke  
 Tel: 01 208 2858  
 Mob: 087 224 2009  
 E-mail: john.clarke@2rn.ie

## **SERVICE SCHEDULE 201**

### **Analogue FM Radio** **Distribution and Transmission** **Service**

#### **INDEX**

- 1. Scope & Objectives**
- 2. Specific Terms and Conditions**
- 3. Service Delivery Requirements**
- 4. Broadcast System Parameters**
- 5. Signal Interface Points**
- 6. Signal Specification**
- 7. Distribution & Transmission System Operation**
- 8. Supervisory Control And Data Acquisition (SCADA)**
- 9. Coverage**
- 10. Standby Electrical Power**
- 11. Service Availability and Service Credits**
- 12. Sample Reports**
- 13. Reference Documents**
- 14. Abbreviations**

**Table 1 List of Sites, Locations and Transmission Site Parameters.**

**Table 2 Points Of Contact.**

## 1.0 Scope & Objective

- 1.1 The provision by the Service Provider 24 hours a day, during each day of each year of the Agreement of an analogue terrestrial FM radio distribution and transmission service to the Client in respect of the Client Audio Transport Stream. Subject to the provisions of Clause 24 (force majeure) of the Agreement, the Service Provider shall ensure that the Client's Audio Transport Stream presented at the Signal Interface Points (as defined in Section 5 below) is distributed via the distribution and transmission System as outlined in Table 1. The Service provided by the Service Provider shall be in compliance with the standards and requirements as set out in this Appendix A.

## 2.0 Specific Terms and Conditions

### 2.1 Initial Term

The provision of the Service is subject to an Initial Term of 10 years (*subject to Client broadcast licence*). Prior to the expiry of the Initial Term, the Parties may agree to extend the Initial Term by a further period of 5 years. Prior to the expiry of the Term, the Parties may agree to extend the Term for successive terms of five years.

- 2.2 Upon Termination of the Agreement, the Parties agree that a Termination Sum will be payable by the Client as follows:

- (i) in the event the Termination Date is prior to the fifth anniversary of the date of this Agreement, as of the Termination Date, the sum of all future Tariff payments, based upon the most recent Tariff Model as of that date (where the operating charge component of the Tariff will be calculated using the most recent operating charge invoiced to the Client prior to the Termination Date), that would have been payable by the Client from the Termination Date to the fifth anniversary of the date of this Agreement including any Tariff payments due but not yet paid, together with an amount equal to the Tariff payable in the 18 month period immediately preceding the Termination Date; or
- (ii) in the event the Termination Date is on or after the fifth anniversary of the date of this Agreement the Termination Sum shall be calculated as follows:

<i>Termination Date</i>	<i>Termination Sum</i>
On or after fifth anniversary of the Agreement but before the sixth anniversary	100 per cent of the Tariff payments payable in the preceding 18 month period
On or after sixth anniversary of the Agreement but before the seventh anniversary	100 per cent of the Tariff payments payable in the preceding 16 month period
On or after seventh anniversary of the Agreement but before the eighth anniversary	100 per cent of the Tariff payments payable in the preceding 14 month period
On or after eighth anniversary of the Agreement but before the ninth anniversary	100 per cent of the Tariff payments payable in the preceding 12 month period

2.3 The provision of the Service is conditional upon the Client providing Security to the value of the Termination Sum.

### 3.0 System Service Delivery Requirements

3.1 The Service Provider shall deliver a service that meets the following minimum service delivery requirements for the System for the Client's Audio Transport Stream:

Service Availability Target at each site:	Operating at, or within, the Upper and Lower Failure Thresholds for 99.8% of the time. Excluding any Non-Ranking Events as specified in Section 11.
---	---

Availability measured over:	Each quarterly calendar period
-----------------------------	--------------------------------

Normal Operating Power per site:	ERP as detailed in Table 1
Normal Operating Frequencies:	As detailed in Table 1

Upper Failure Threshold:	> Normal Operating Power + 1dB
Lower Failure Threshold:	< Normal Operating Power - 3dB

ERP = Effective Radiated Power

3.2 The Service Provider shall radiate the Effective Radiated Power (ERP) indicated in Table 1. The ERP shall be delivered utilising a defined antenna pattern that shall ensure that network and international interference are minimised and any International restrictions are complied with in so far as is reasonably possible.

3.3 The Service Provider shall comply with the relevant parts of the ComReg Licence obligations when such obligations having been notified to the Service Provider by the Client.

3.4 The Service Provider shall ensure that the service delivered complies with the engineering performance measures detailed below.

3.5 Engineering Performance Measures:

#### 3.5.1 Maintenance Limits for VHF FM Transmitters

Frequency Deviation	$\pm 75$ KHz (Mod. capability: $\pm 100$ KHz)
Pre-emphasis	50 $\mu$ S Audio Frequency Response (Mono)
	$\pm 0.5$ dB between 30Hz – 15 KHz.
Total Harmonic Distortion (Mono)	-50 dB or better, 30 Hz-15 KHz.
Noise (Unweighted) @ 75 KHz dev.	-70 dB or better. (Stereo /Mono)
(Weighted)*	-68 dB or better. (Stereo/Mono)
Audio Frequency Response (Stereo)	$\pm 0.5$ dB between 30Hz – 15 KHz.
Total Harmonic Distortion:	
(@ 75 KHz)	-50 dB or better, 30 Hz-15 KHz
(@100 KHz)	-46 dB or better, 30 Hz-15 KHz
Intermodulation Distortion (2-tone)	-55 dB or better, second order.
	-50 dB or better, third order.

\* In accordance with CCIR Rec 468-4 specification.

### 3.5.2 Maintenance Limits for VHF FM Transposers & Relays

Frequency Deviation	±75 KHz (Mod capability: ± 100 KHz)
Pre-emphasis	75µS
Audio Frequency Response (Mono)	± 0.5 dB between 30Hz – 15 KHz.
Total Harmonic Distortion (Mono)	-50 dB or better, 30 Hz-15 KHz.
Noise (Unweighted) @ 75 KHz dev.	-68 dB or better. (Stereo /Mono)
(Weighted) *	-65 dB or better. (Stereo/Mono)
Audio Frequency Response (Stereo)	± 0.5 dB between 30Hz – 15 KHz
Total Harmonic Distortion:	
(@75KHz deviation)	-50 dB or better, 30 Hz-15KHz
(@100 KHz deviation)	-46 dB or better, 30 Hz-15 KHz
Intermodulation Distortion (2-tone)	-55 dB or better, second order.
	-50 dB or better, third order.

\* In accordance with CCIR Rec 468-4 specification.

## 4.0 Broadcast System Parameters

- 4.1 The Client will present, or arrange to have presented, the agreed Audio Transport Stream at the Signal Interface Points, from which the Service Provider will accept, distribute and transmit it on the frequencies and from the transmission sites listed in Table 1 attached. The Service Provider shall ensure that the Audio Transport Stream is only transmitted from its sites on frequencies authorised for this purpose.
- 4.2 Subject to Clause 3 (Term) of the Agreement, the Service Provider will transmit from the locations listed in Table 1.

## 5.0 Signal Interface Points

- 5.1 The Client shall present two diverse and separate feeds for the Audio Transport Stream at two Signal Interface Points for distribution to, and transmission from, the transmission sites detailed in Table 1.

The Service Provider has two Signal Interface Points at its premises at Cookstown Court in Tallaght, Dublin 24 and has a further two Signal Interface Points located adjacent to the tower on the RTÉ campus in Donnybrook Dublin 4.

- 5.2 Transposer sites will receive their input source signals from one of the main transmission sites, or another Transposer site, as per Table 1, and retransmit.

## 6.0 Signal Specification

- 6.1 The Audio Transport Stream presented by the Client to the Service Provider at the Signal Interface Point shall be:
- Audio Left – Line level Audio (0dBu 1mW into 600Ω)
  - Audio Right - Line level Audio (0dBu 1mW into 600Ω)

- Radio Data System (RDS) Data Stream.
- Copper Wire Physical Interface

## **7.0 Distribution & Transmission System Operation**

The Clients Audio Transport Stream presented at the Signal Interface Points shall be transported to eleven main transmission sites via a combination of fibre optic cables and microwave radio links and shall be transmitted from those sites.

### **7.1 Distribution**

Each Audio Transport Stream is multiplexed with other services and distributed to the transmission sites. The Service Provider utilises interconnected equipment at Cookstown Court in Tallaght and at RTÉ in Donnybrook to achieve diverse connectivity to the microwave radio distribution system. An overview is shown in Figure 7.1.1.

**Figure 7.1.1 Distribution overview**

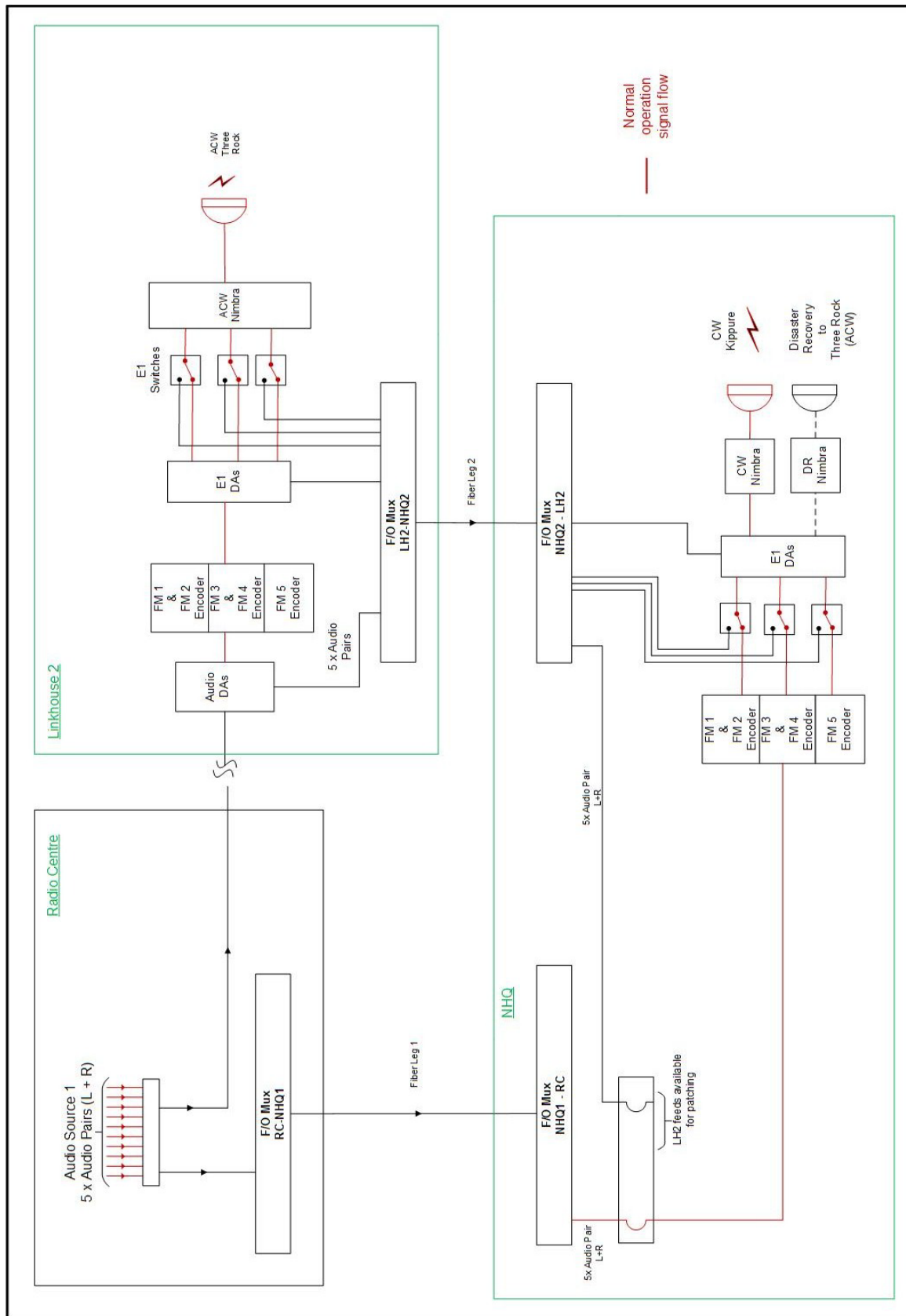

The primary distribution system consists of two STM-1 microwave radio circuits with two radial spurs. An overview of the microwave radio distribution system is shown in Figure 7.1.2. *[Please Note The Service provider is currently in the process of migrating its distribution system to a hybrid fibreoptic/fixed radio link network and this section 7.1 is subject to change.]*

**Figure 7.1.2 Distribution system overview**

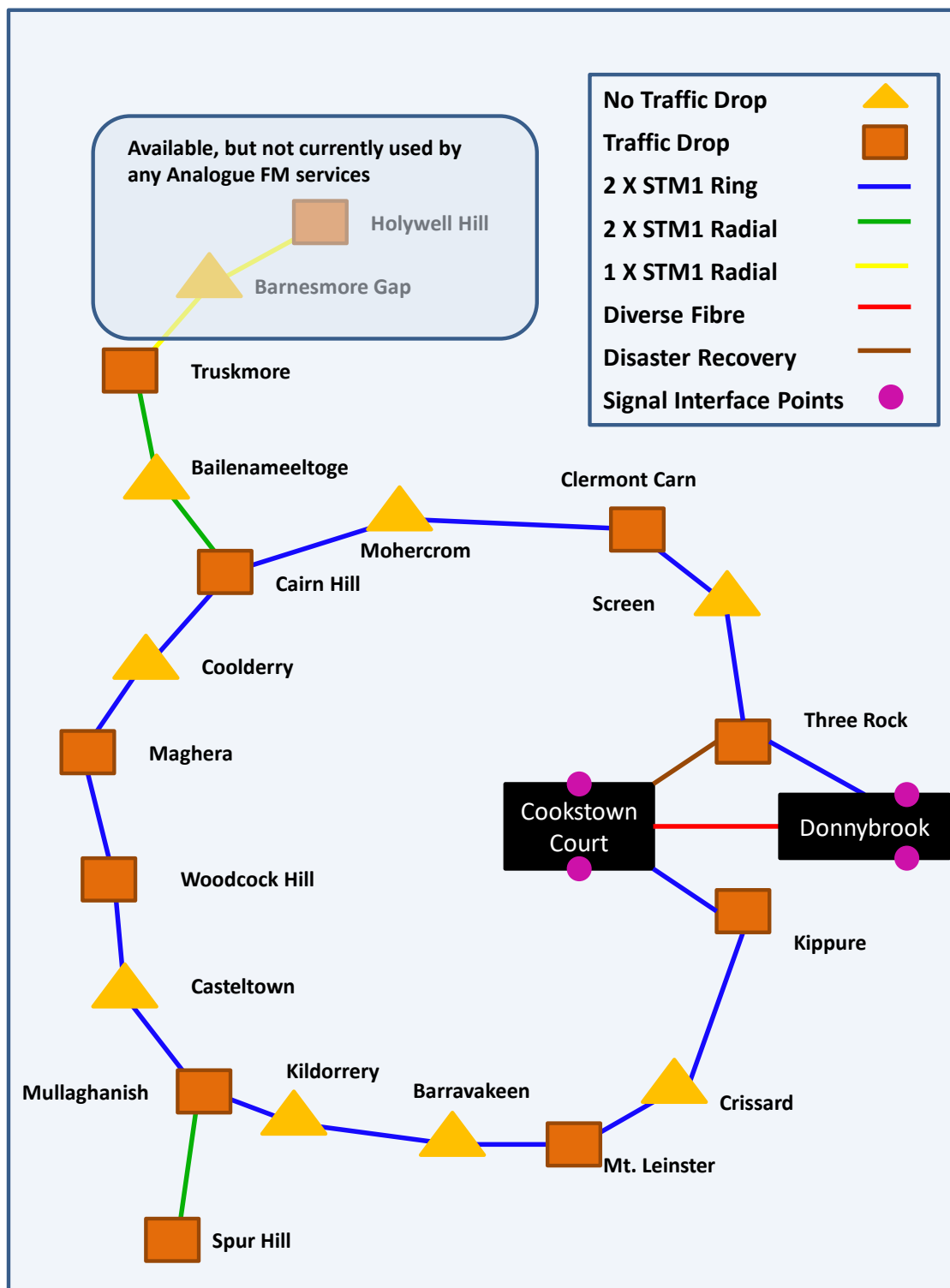

## 7.2 Transmission

At the main transmission sites the Audio Transport Stream is fed to the transmitters which produce an RF signal at the specified power.

At the main transmission sites each antenna is constructed in two halves and each half has its own feeder cable. The overarching design criterion is that the antenna can facilitate full power into either half.

At the main transmission sites each Audio Transport Stream has its own transmitter. The Service Provider employs solid state transmitters which have dual drives and multiple output modules and therefore degrade gracefully in the vast majority of fault situations.

The outputs from the active transmitters are combined and the power split across the two halves of the antenna.

An overview of the arrangement for main sites can be seen in Figure 7.2.1.

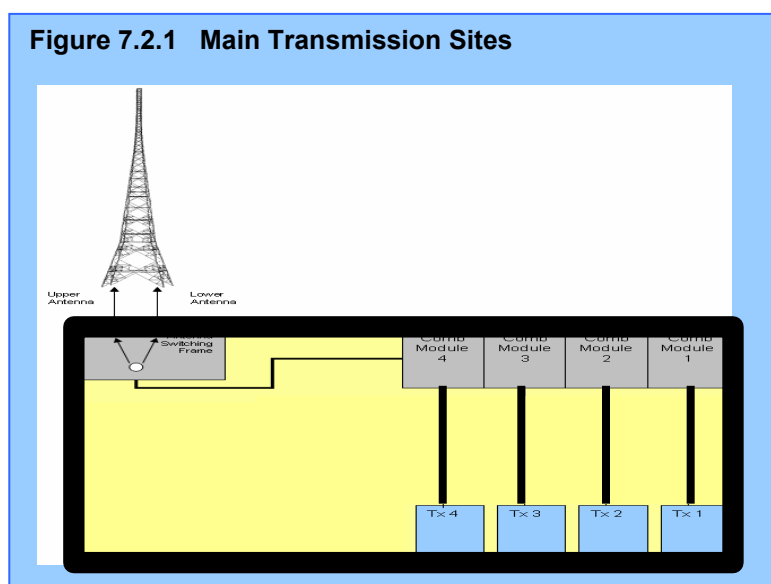

## 7.3 Network Monitoring Centre (NMC)

7.3.1 The Service Provider operates a Network Monitoring Centre (NMC) in which the status and control of all elements of network infrastructure is monitored. The NMC provide a staffed point of contact (contact details in Table 2) through which all enquiries and fault notices and other reports are channelled and logged, during NMC staffed hours. Each week of the year, depending on operational demands, the NMC is staffed during the period 07:00 to 23:00 from Monday to Friday inclusive, and 08:00 to 22:00 on Saturday and Sunday. Outside of NMC staffed hours calls and enquiries are registered or recorded electronically for attention next day.

7.3.2 All relevant enquiries, fault notices, or other reports conveyed by telephone, email, or otherwise, to the Service Provider are logged on a fault database.

7.3.3 Every fault incident identified by, or reported to, the NMC, including those from the Service Provider staff, are given a unique call reference number and the logging process captures all the relevant details pertinent to the call. The logging system is used as the basis for tracking faults to resolution, and generation of reports.

Details logged shall include the following:

- Name of the caller (if applicable)
- Date and time
- Transmission site location (if known)
- Contact number (if applicable)
- Service affected
- Description of the nature of the fault
- Fault category level.

7.3.4 All relevant alarms raised by the Service Provider's SCADA system (Supervisory Control and Data Acquisition) are logged.

7.3.5 The NMC processes all calls through to a successful conclusion and ensure that the Client will be able to obtain updates on all incidents from a single point of contact.

#### 7.4 Fault Incidents

7.4.1 During the staffed hours of the NMC. When the NMC receives information on a fault incident it is logged. Where the fault is with the System a fault response is initiated by the NMC. Where the fault incident is not with the System, but is within the responsibility of the Client, and/or any Authorised Representative nominated by the Client, the NMC will contact the Client as soon as possible by email and/or telephone as per Section 7.3.

7.4.2 When received, each fault incident shall be assessed and appointed a level of severity. In the event that the Client, and/or any Authorised Representative nominated by the Client, and the NMC / on-call engineer cannot agree which severity level should be allocated to the fault, the matter will be referred to each representative's immediate superior for determination. During any disagreement between the Client, and/or any Authorised Representative nominated by the Client, and the Service Provider on the severity level to be appointed the more severe, higher level, will be used.

7.4.3 Outside the staffed hours of the NMC the scheduled on-call engineer will be alerted to all relevant alarms raised by the Service Provider's SCADA / automated alarm system. The relevant information will be communicated to the NMC the following morning for processing as per Section 7.3.

7.4.4 The following list describes the fault level categories.

Category	Disruption
Level 1 >= Main Transmitter Site Faults	<p>5. Total loss of, or a reduction in Power greater than Lower Failure Threshold in, the output of any main transmission site.</p> <p>6. Total failure of the primary distribution system (Microwave Radio Links system) at the site or location.</p>
Level 2 >= Priority Relay or Priority Transposer Site Faults	<p>5. Total loss of, or a reduction in Power greater than Lower Failure Threshold in, the output of any priority transposer or priority relay transmission site.</p> <p>6. Total failure of the secondary distribution system (Rebroadcast) at a priority transposer site.</p>
Level 3 >= Transposer or Relay Site Faults	<p>5. Total loss of, or a reduction in Power greater than Lower Failure Threshold in, the output of any transposer or relay transmission site.</p> <p>6. Total failure of the secondary distribution system (Rebroadcast) at a transposer or re-transmitter site.</p>
Level 4	Any other fault

7.4.5 Subject to Clause 3 (Term), the Client may from time to time require the Service Provider to investigate documented generalised complaints concerning the Client's coverage/signal strength in areas where adequate coverage is predicted by the Service Provider.

7.4.5.1 The Service Provider will be entitled to levy additional fees for such work, where such work is not covered by a pre-existing obligation under this Agreement and where the investigation proves that coverage/signal strength is as predicted. The Service Provider will conduct two investigations (maximum of three man days each) per Audio Transport Stream per year without levying additional fees.

7.4.5.2 The Service Provider will not be entitled to levy additional fees for such work, where such work is covered by a pre-existing obligation under this Agreement and where the investigation proves that coverage/signal strength is not as predicted. The Client may be entitled to a Service Credit under Section 11 in this situation.

## 7.5 Fault Response

7.5.1 During the staffed hours of the NMC. The NMC shall undertake an initial investigation and where appropriate ask the engineer(s) at work or on-call to verify the existence of a fault. Once a fault has been identified, it is addressed and processed in line with the procedure outlined in Section 7.3. Outside of the engineer's normal working hours, if necessary the NMC will alert the on-call engineer(s) to attend the fault(s).

7.5.2 Outside the staffed hours of the NMC. The scheduled on-call engineer shall undertake an initial investigation and verify the existence of a fault. Once a fault has been identified, it is addressed and the relevant information communicated to the NMC the following morning for processing as per Section 7.3.

7.5.3 In the event that any level fault cannot be resolved by remote control a Service Provider engineer (subject to Sub Sections 7.5.5, 7.5.6, 7.5.7 and 7.5.8 below) shall

attend the site of the fault within the "Maximum Response Time" as detailed in Table 1.

- 7.5.4 For the purposes of this Agreement, "Maximum Response Time" shall mean the time between the Service Provider first becoming aware of a Level 1, Level 2 or Level 3 fault at a site, either through its own monitoring or by a confirmed report from the Client and the arrival at the site of suitably trained and skilled personnel to investigate and seek to remedy such fault, or the resolution of the fault by other means. This is the maximum response time and the Service Provider would expect to, and endeavour to, attend all faults substantially inside this maximum.
- 7.5.5 For Level 1 faults, when site attendance is required, and when it is not possible for an engineer to attend site where the fault is located at or before 23:30 from Monday to Sunday an engineer will attend the following day, at or before 06:30 on Monday to Friday and at or before 08:00 on Saturday and Sunday.
- 7.5.6 For Level 2 faults, when site attendance is required, when it is not possible for an engineer to attend site where the fault is located at or before 23:30 from Monday to Sunday an engineer will attend the following day, at or before 08:00 Monday to Sunday.
- 7.5.7 For Level 3 faults, when site attendance is required, during the periods 08:00 to 18:45 on each of the seven days of each week of the year, when it is not possible for an engineer to attend the site where the fault is located at or before 18:45 an engineer will attend at or before 08:00 the following day.
- 7.5.8 Level 4 faults will be addressed during normal working hours, 08:00 to 18:45 Monday to Friday.
- 7.5.9 During the staffed hours of the NMC. The NMC shall notify the Client by email of all fault incidents and keep the Client updated as in accordance with the following:

<b>Category</b>	<b>Time interval</b>
Level 1	Before 30 minutes and then every 3 hours.
Level 2	Before 30 minutes and then every 6 hours.
Level 3	Before 7 days and them Monthly by report.
Level 4	Monthly by report

## 7.6 Escalation Process

7.6.1 The Service Provider shall respond to faults in accordance with the time limits described in this Section 7.5. In the event that resolution of a fault does not occur as outlined in Section 7.5, it is agreed that the Client may escalate the fault response process according to the following timetable:

Category	Client	Service Provider	Time interval
Level 1	?????	NMC Engineer	After 1 hour
	& ??????	& Operations Manager	After 3 hours
	& ????????????	& Executive Director	After 6 hours
Level 2	????????????	NMC Engineer	After 2 hours
	& ????????????	& Operations Manager	After 4 hours
	& ??????????	& Executive Director	After 8 hours
Level 3	????????????	NMC Engineer	After 5 days
	& ????????????	& Operations Manager	After 8 days
	& ????????????	& Executive Director	After 14 days
Full contact details are included as Table 2			

7.6.2 Escalation will be deemed to occur where the Client considers that there has been a failure to provide the agreed level of service. The Service Provider will in these circumstances empower suitable personnel with a level of authority, control and resources to ensure the Service Provider meets the agreed level of service.

## 7.7 Reporting

7.7.1 The NMC manager shall, on a monthly basis, make available on the Service Providers website an overview performance report for each Audio Transport Stream. Report sample templates are attached in section 12 of this Appendix A. The report will incorporate a table showing the actual performance for the month for each metric, and the target performance for that metric. The table will be followed by text briefly explaining the reason for any shortfall against target and/or any missing metrics.

7.7.2 In the case of Level 1 and 2 faults, upon request from the Client to the NMC, a report on the individual event will be promptly prepared and issued by the NMC manager.

7.7.3 The Client and/or the Service Provider may request a formal review meeting in the event that one or more of the System service commitments in this Agreement are not met.

## 7.8 Routine Meetings

7.8.1 A general review meeting will be held every three months between Authorised Representatives from the Client and the Service Provider (Authorised

Representatives will be identified by the Client and the Service Provider in Table 2). The function of these meetings will be to:

- To review the System performance in the previous period.
- To discuss and resolve any outstanding issues arising.
- To address any upcoming requirements.
- Update personnel/contact changes or other changes in Appendixes A, B and C.

#### 7.8.2 Documentation – records.

7.8.2.1 The Service Provider shall make sure that it keeps accurate, complete and up to date records for the term of this Agreement and for 3 years after its expiry or termination.

7.8.2.2 The Service Provider shall retain the information required to evidence compliance with its obligations under this Agreement.

### 7.9 Maintenance

Routine preventative maintenance will be undertaken primarily during normal working hours. This will particularly be the case for antenna maintenance for Health & Safety reasons. All reasonable efforts will be made to ensure minimal interruptions to the distribution and transmission service and the Client, and/or any Authorised Representative nominated by the Client, will be given 5 days' notice of any work which may have a direct impact on the distribution or transmission of the Audio Transport Stream to viewers. Notification of service effecting outages or power reductions (to a level below the Lower Failure Threshold) shall be issued with a minimum notice period of 5 calendar days using the Outage Notification Form (sample in section 12.2). The works as described in Outage Notification Form shall proceed as outlined unless commented upon by the Client, and/or any Authorised Representative nominated by the Client, within 2 calendar days of the Outage Notification Form being issued.

Masts, antenna, combiners and other common equipment are used for more than one client. Where agreement cannot be reached with all clients in relation to power reductions (to a level below the Lower Failure Threshold) or outages the Service Provider reserves the right for the Service Provider Executive Director to adjudicate.

Maintenance on the distribution system will be managed to ensure that, where it is necessary to take a distribution feed out of service, the alternative feed is available and put into service.

For antenna system maintenance, where possible, maintenance will be undertaken by switching to a reserve antenna, where available, or to “half stack” operation. Where this is not possible, interruptions to the transmission will be kept to a minimum and agreed in advance.

## **8.0 Supervisory Control And Data Acquisition (SCADA)**

8.1 In addition to the monitoring of the integrity of the Audio Transport Stream at the Signal Interface Points and transmitter outputs as outlined in Section 3 and 7 of this Appendix A, the Service Provider operates a SCADA system and this is used to control and monitor the System performance. There are two levels of interface with the transmission sites:

8.1.1 Monitoring. The SCADA system monitors a number of preset parameters on the transmission equipment and at the Signal Interface Points and raises, reminders, alarms, notifications, etc.

8.1.2 Control and Monitoring: As 8.1.1 but also allows Engineers and/or the NMC to undertake a number of tasks remote from the transmission site such as switching, resetting, parameter adjustments, etc.

8.2 Table 1 attached identify the SCADA service available at each transmission site.

## **9.0 Coverage**

9.1 Coverage is not guaranteed. The Table in Section 11 indicates the percentage of population covered from each transmission site. The coverage figures are generated using ATDI coverage modelling software input with the best available information.

Site Information: Location, Height, etc.

System Parameters: ERP, Antenna Patterns, etc.

Landscape: Geographical, Topological, Population, Clutter, etc.

## **10.0 Standby Electrical Power**

10.1 All sites with backup generators are identified in Table 1. These sites are fitted with generators that automatically start-up and provide electrical power in the event that the electrical mains fail. A short interruption to services is experienced at mains failure and mains restore to facilitate source switching.

10.2 As a minimum, each generator shall have sufficient fuel capacity available on site to run continuously for a period of three days.

## **11.0 Service Availability and Service Credits**

### **11.1 Introduction**

The FM Broadcast System is designed, installed and operated to provide listeners, the population, with the highest availability that can be cost-effectively, and efficiently, obtained. Delivering the Client's Audio Transport Stream to the population is the purpose of the FM Broadcast System and therefore Service Availability is measured in terms of, and directly linked to, the population covered by each Site. Similarly Service Credits are also linked to each Site and the population it covers.

### **11.2 Service Availability Target**

11.2.1 The Service Availability Target for each Site is that it operates at, or within, the Upper and Lower Failure Thresholds for 99.8% of the time, as specified in Appendix A, excluding Non-Ranking Events, as specified in Section 11.3 below.

### 11.3 Non-Ranking Events

The following Non-Ranking Events are necessary for the operation and maintenance of the FM Service, or are outside the Service Provider's reasonable control:-

- 11.3.1 A failure or interruption resulting from the Client's, and/or any Authorised Representative nominated by the Client, refusal to permit such work on any Equipment as the Service Provider reasonably regards as essential;
- 11.3.2 Where resulting from the Service Provider's due compliance with safe working practices stipulated by a Competent Authority or any other health, safety, environmental or other law or generally recognised protocol or standard (whether or not having the force of law);
- 11.3.3 Impairment of the quality of the Audio Transport Stream transmitted directly to the viewer due to anomalous propagation conditions;
- 11.3.4 Any fault requiring mast ascent during the hours of darkness or severe inclement weather where, in reasonable judgement of the Service Provider, a potential safety hazard exists;
- 11.3.5 Any breach of this Agreement by the Client, and/or any Authorised Representative nominated by the Client;
- 11.3.6 Any interruption (other than as a result of a breach by the Service Provider) as a result of:
  - 11.3.6.1 The Service Provider complying with a direction from any Competent Authority under the Licences, or from any court of competent jurisdiction requiring the Service Provider or Client, and/or any Authorised Representative nominated by the Client, to cease or suspend transmission, or;
  - 11.3.6.2 The Client, and/or any Authorised Representative nominated by the Client, complying with a direction from any Competent Authority to suspend broadcasting;
- 11.3.7 Any interruption as a result of an engineering test transmission made at the request of the Client, and/or any Authorised Representative nominated by the Client, where the potential effects of the test have been previously discussed by the Client, and/or any Authorised Representative nominated by the Client, and the Service Provider;
- 11.3.8 Any fault requiring attendance at a Site during any period where such attendance is not permitted or is otherwise prevented as a consequence of a security alert or any other Force Majeure event or where the Service Provider is not allowed full and immediate access;
- 11.3.9 Any maintenance work undertaken by the Service Provider pursuant to Section 7;
- 11.3.10 Failure by the Client, and/or any Authorised Representative nominated by the Client, to deliver a valid signal as per Section 6;
- 11.3.11 Any Force Majeure event as contemplated by Clause 23 of the Agreement;
- 11.3.12 A reduction in nominal ERP to a level not below the Lower Failure Threshold for operational or maintenance works.
- 11.3.13 An outage or reduction in nominal ERP to a level below the Lower Failure Threshold where the Client, and/or any Authorised Representative nominated by the Client, is given prior notice and the Client, and/or any Authorised Representative nominated by the Client, do not raise an objection;

- 11.3.14 Interruptions to the System for up to 60 seconds;
- 11.3.15 Electrical supply failures excepting sites where backup generation is present as per Table 1 of this Appendix A;
- 11.3.16 Interruptions to the primary or secondary distribution systems as a result of anomalous propagation or interference effects, including obstructions, which are outside the Service Provider's reasonable control. The Service Provider will work with planners, developers, County Councils and any other relevant authority to monitor the possibility of obstructions occurring and will notify the Client upon becoming aware of the possibility of an obstruction;
- 11.3.17 Any interruption resulting from defects or failures in the equipment or services provided or operated by, or on behalf of, the Client, and/or any Authorised Representative nominated by the Client, (other than equipment which the Service Provider is required to operate and maintain under this specific Agreement);
- 11.3.18 The Service Provider undertaking any other major works, such as a mast or antenna system replacement, where the outages and / or power reductions are necessary and have been requested and agreed in advance by the Client, and/or any Authorised Representative nominated by the Client.
- 11.3.19 Any service or power reduction undertaken as specified in Clause 5.4 of the Agreement.

#### 11.4 Service Credits

- 11.4.1 At the end of each calendar quarter the Service Provider shall calculate for each Site the total amount of time, if any, that the FM Service did not meet the Service Availability Target, as specified in Section 3.2 above.
- 11.4.2 When the actual time of service availability over the calendar quarter is less than the Service Availability Target the following formula shall be applied to calculate the Service Credit that is Payable to the Client:

$$\text{Service Credit Payable} = C \times P \times D$$

where:

C = the per minute Charge/Tariff for the Service(s) at all Sites for the period;

P = the weighted population coverage percentage for each Site (including any dependants) as set out in the table below. Colum labelled 'Weighted % for Service Credit calculations';

D = the number of minutes that the Site was below the Service Availability Target in the quarter.

Example: the Radio X FM service at Spur Hill has operated outside of the failure thresholds, and below the Service Availability Target, for a period of 45 minutes;

The Service Credits will therefore be based on the following:

C = €1.90	(Per minute, based on a national FM example tariff of €1.0m. €1m / minutes in year).	
P = 3.450%	(Spur Hill based on table below).	
D = 45	(minutes)	

$$\begin{aligned} \text{Spur Hill Service Credit Payable} &= C \times P \times D \\ &= 1.90 \times 0.0345 \times 45 \end{aligned}$$

Sub Total = €2.95

Spur Hill has an RBR dependant Collins Barracks.

C = €1.90 (Per minute, based on a national FM example tariff of €1.0m. €1m / minutes in year).

P = 1.052% (Collins Barracks based on table below).

D = 45 (minutes)

$$\begin{aligned} \text{Collins Barracks Service Credit Payable} &= C \times P \times D \\ &= 1.90 \times 0.01052 \times 45 \end{aligned}$$

Sub Total = €0.90

TOTAL = €3.85

- 11.4.2.1 For the avoidance of doubt, the amount used for C in the above formula shall be from the Tariff Model for the year in which the quarter falls.
- 11.4.2.2 The Service Provider shall notify the Client, and/or any Authorised Representative nominated by the Client, of the period, nature and timing of all faults at each Site.

SITES	COUNTY	RTÉ RADIO 1		RTÉ 2FM		RTÉ Lyric FM		RTÉ RnG		
		Best Server: Indoor (% Households)	Weighted % for Service Credit Calculations	Best Server: Indoor (% Households)	Weighted % for Service Credit Calculations	Best Server: Indoor (% Households)	Weighted % for Service Credit Calculations	Best Server: Indoor (% Households)	Weighted % for Service Credit Calculations	
1	Cairn Hill	Longford	3.910	4.113						
2	Clermont Carn	Louth	4.950	5.207	5.230	5.579	5.230	5.551	5.230	5.551
3	Holywell Hill	Donegal	0.840	0.884	0.840	0.896	0.840	0.892	0.840	0.892
4	Kippure	Wicklow	22.370	23.533	23.030	24.565	23.040	24.453	23.040	24.453
5	Maghera	Clare	8.820	9.278	9.660	10.304	10.120	10.741	10.120	10.741
6	Mt Leinster	Carlow	9.650	10.151	10.460	11.157	10.460	11.102	10.460	11.102
7	Mullaghanish	Cork	6.040	6.354	6.040	6.443	6.040	6.411	6.040	6.411
8	Spur Hill	Cork	3.280	3.450	3.280	3.499	3.280	3.481	3.280	3.481
9	Three Rock	Dublin	11.190	11.772	11.190	11.936	11.190	11.876	11.190	11.876
10	Truskmore	Sligo	3.730	3.924	5.020	5.355	5.020	5.328	5.020	5.328
11	Castlebar	Mayo	2.150	2.262	2.160	2.304	2.160	2.293	2.160	2.293
12	Clonmel	Waterford	0.700	0.736	0.710	0.757	0.710	0.754	0.710	0.754
13	Cnoc an Or	Kerry	0.540	0.568	0.540	0.576	0.540	0.573	0.540	0.573
14	Crosshaven	Cork	1.090	1.147	1.090	1.163	1.090	1.157	1.090	1.157
15	Dungarvan	Waterford	1.050	1.105	1.050	1.120	1.050	1.114	1.050	1.114
16	Gallows Hill	Waterford	0.550	0.579	0.550	0.587	0.550	0.584	0.550	0.584
17	Greystones	Wicklow	0.720	0.757	0.720	0.768	0.720	0.764	0.720	0.764
18	Kilduff	Tipperary	1.500	1.578	0.000	0.000				
19	Knockmoyle	Kerry	1.310	1.378	1.310	1.397	1.310	1.390	1.310	1.390
20	Monaghan	Monaghan	0.860	0.905	1.010	1.077	1.010	1.072	1.010	1.072
21	Suir Valley	Kilkenny	0.540	0.568	0.540	0.576	0.540	0.573	0.540	0.573
22	Woodcock Hill	Clare	3.230	3.398	3.240	3.456	3.240	3.439	3.240	3.439
23	Achill	Mayo	0.390	0.410	0.390	0.416	0.390	0.414	0.390	0.414
24	Aranmore	Donegal	0.410	0.431	0.410	0.437	0.410	0.435	0.410	0.435
25	Athlone	Westmeath	0.460	0.484	0.500	0.533	0.500	0.531	0.500	0.531
26	Ballybofey	Donegal	0.370	0.389	0.370	0.395	0.370	0.393	0.370	0.393
27	Ballydavid	Kerry	0.060	0.063	0.060	0.064	0.060	0.064	0.060	0.064
28	Bantry	Cork	0.270	0.284	0.270	0.288	0.270	0.287	0.270	0.287
29	Casla	Galway	0.220	0.231	0.220	0.235	0.220	0.233	0.220	0.233
30	Castletownbere	Cork	0.300	0.316	0.300	0.320	0.300	0.318	0.300	0.318
31	Clifden	Galway	0.260	0.274	0.260	0.277	0.260	0.276	0.260	0.276
32	Collins Barracks	Cork	1.000	1.052	1.000	1.067	1.000	1.061	1.000	1.061
33	Fanad	Donegal	0.610	0.642	0.610	0.651	0.610	0.647	0.610	0.647
34	Fermoy	Cork	0.260	0.274	0.260	0.277	0.260	0.276	0.260	0.276
35	Kilkeaveragh	Kerry	0.250	0.263	0.250	0.267	0.250	0.265	0.250	0.265
36	Kinsale	Cork	0.110	0.116	0.110	0.117	0.110	0.117	0.110	0.117
37	Lehinch	Clare	0.190	0.200	0.190	0.203	0.190	0.202	0.190	0.202
38	Maamclassach	Kerry	0.030	0.032	0.030	0.032	0.030	0.032	0.030	0.032
39	Magheraroarty	Donegal	0.140	0.147	0.140	0.149	0.140	0.149	0.140	0.149
40	Malin	Donegal	0.270	0.284	0.270	0.288	0.270	0.287	0.270	0.287
41	Mitchelstown	Limerick	0.200	0.210	0.200	0.213	0.200	0.212	0.200	0.212
42	Moville	Donegal	0.240	0.252	0.240	0.256	0.240	0.255	0.240	0.255
			95.060	100.000	93.750	100.000	94.220	100.000	94.220	100.000

## 12.0 Sample Reports

### 12.1 Sample Outage Report:



**Transmission Outage Report**

**Reference Number:**

**Date:**

**Service(s):**

**Transmission Site(s):**

**Time / Duration of Outage:**

**Report Compiled By:**

**Fault / Outage Summary:**

**Notifications:**

**Details Of Cause & Remedial Actions:**

12.2 Sample Outage Notification Form



**Transmission Outage Notification Form**

**Reference Number:**

**Date:**

**Service(s):**

**Transmission Site(s):**

**Time / Duration of Outage:**

**Details:**

### 12.3 Sample Availability Report

Monthly Service Availability Figures (Including Electricity Supply Outages)														
2009		Jan	Feb	Mar	Apr	May	Jun	Jul	Aug	Sep	Oct	Nov	Dec	Year
ATT	RTÉ One	99.9924	99.9999	99.9999	99.9999	99.9999	99.9999	99.9999	99.9999	99.9999	99.9999	99.9999	99.9999	99.9993
	RTÉ Two	99.9999	99.9916	99.9999	99.9999	99.9999	99.9999	99.9999	99.9999	99.9999	99.9999	99.9999	99.9999	99.9992
	TV3	99.9999	99.9999	99.9841	99.9999	99.9999	99.9999	99.9999	99.9999	99.9999	99.9999	99.9999	99.9999	99.9986
	TG4	99.9999	99.9999	99.9999	99.3284	99.9999	99.9999	99.9999	99.9999	99.9999	99.9999	99.9999	99.9999	99.9439
DTT	Mux 1				99.9999	99.9999	99.2358	99.9999	99.9999	99.9999	99.9999	99.9999	99.9999	99.9150
	Mux 2				99.9999	99.9999	99.9999	99.8654	99.9999	99.9999	99.9999	99.9999	99.9999	99.9650
	Mux 3				99.9999	99.9999	99.9999	99.9999	99.9756	99.9999	99.9999	99.9999	99.9999	99.9972
	Mux 4				99.9999	99.9999	99.9999	99.9999	99.9999	99.9962	99.9999	99.9999	99.9999	99.9995
Radio	RTÉ Radio 1	99.9999	99.9999	99.9999	99.9999	99.9999	99.9999	99.9999	99.9999	99.9653	99.9999	99.9999	99.9999	99.9970
	RTÉ 2FM	99.9999	99.9999	99.9999	99.9999	99.9999	99.9999	99.9999	99.9999	99.9999	99.9423	99.9999	99.9999	99.9951
	RTÉ RnaG	99.9999	99.9999	99.9999	99.9999	99.9999	99.9999	99.9999	99.9999	99.9999	99.9999	99.8642	99.9999	99.9886
	RTÉ Lyric	99.9999	99.9999	99.9999	99.9999	99.9999	99.9999	99.9999	99.9999	99.9999	99.9999	99.9999	99.9756	99.9979
	Today FM	99.9999	99.9999	99.9999	99.9999	99.9999	99.9999	99.9999	99.9999	99.9999	99.9999	99.9999	99.9782	99.9981

Monthly Service Availability Figures (Excluding Electricity Supply Outages)														
2009		Jan	Feb	Mar	Apr	May	Jun	Jul	Aug	Sep	Oct	Nov	Dec	Year
ATT	RTÉ One	99.9924	99.9999	99.9999	99.9999	99.9999	99.9999	99.9999	99.9999	99.9999	99.9999	99.9999	99.9999	99.9993
	RTÉ Two	99.9999	99.9916	99.9999	99.9999	99.9999	99.9999	99.9999	99.9999	99.9999	99.9999	99.9999	99.9999	99.9992
	TV3	99.9999	99.9999	99.9841	99.9999	99.9999	99.9999	99.9999	99.9999	99.9999	99.9999	99.9999	99.9999	99.9986
	TG4	99.9999	99.9999	99.9999	99.3284	99.9999	99.9999	99.9999	99.9999	99.9999	99.9999	99.9999	99.9999	99.9439
DTT	Mux 1				99.9999	99.9999	99.2358	99.9999	99.9999	99.9999	99.9999	99.9999	99.9999	99.9150
	Mux 2				99.9999	99.9999	99.9999	99.8654	99.9999	99.9999	99.9999	99.9999	99.9999	99.9650
	Mux 3				99.9999	99.9999	99.9999	99.9999	99.9756	99.9999	99.9999	99.9999	99.9999	99.9972
	Mux 4				99.9999	99.9999	99.9999	99.9999	99.9999	99.9962	99.9999	99.9999	99.9999	99.9995
Radio	RTÉ Radio 1	99.9999	99.9999	99.9999	99.9999	99.9999	99.9999	99.9999	99.9999	99.9653	99.9999	99.9999	99.9999	99.9970
	RTÉ 2FM	99.9999	99.9999	99.9999	99.9999	99.9999	99.9999	99.9999	99.9999	99.9999	99.9423	99.9999	99.9999	99.9951
	RTÉ RnaG	99.9999	99.9999	99.9999	99.9999	99.9999	99.9999	99.9999	99.9999	99.9999	99.9999	99.8642	99.9999	99.9886
	RTÉ Lyric	99.9999	99.9999	99.9999	99.9999	99.9999	99.9999	99.9999	99.9999	99.9999	99.9999	99.9999	99.9756	99.9979
	Today FM	99.9999	99.9999	99.9999	99.9999	99.9999	99.9999	99.9999	99.9999	99.9999	99.9999	99.9999	99.9782	99.9981

### 13.0 Reference Documents

ITU-R Rec 647 or S/PDIF	AES/EBU Signal Format.
ITU-T Rec J.41	Companded Mode resolution.
ITU-T Rec J.17	Pre/De-Emphasis.
DIN 45 403	Intermodulation.
CCIR Rec 468-4	"Measurement of Audio frequency noise voltage levels in Sound Broadcasting. "
CCIR Rec 450-1	"Transmission Standards for FM Sound Broadcasting at VHF."
ETS 300 384(CCIR Rec 450)	VHF FM Sound Broadcasting Transmitters.

### 14.0 Abbreviations

ATDI	Advanced Topographic Development & Images Limited
ASI	Asynchronous Serial Interface
BAI	Broadcasting Authority of Ireland
FM	Frequency Modulated
NMC	Network Monitoring Centre
RDS	Radio Data System
SCADA	Supervisory Control and Data Acquisition
STM-1	Synchronous Transport Module - a microwave radio circuit
VHF	Very High Frequency

**FM TABLE 1 Site Data**

SITES	COUNTY	RTÉ Radio 1		RTÉ 2FM		RTÉ Lyric FM		RTÉ RnaG		Details					
		Frequency (Mhz)	Effective Radiated Power (in dBW)	Frequency	Effective Radiated Power (in dBW)	Frequency	Effective Radiated Power (in dBW)	Frequency	Effective Radiated Power (in dBW)	Transmission Site Type M = Main R = Relay T = Transposer/ Re-transmitter/ Priority Relay PT = Priority Transposer/ Re-transmitter	Antenna Polarity H = Horizontal V = Vertical	Signal Source Available L1 = Ring L2 = Spur Main Re-Broadcast Source	Electricity Backup Generator	2 Stack Antenna	SCADA C = Control M = Monitoring
1   Cairn Hill	Longford	89.8	39.9	97.0	46.7	87.8	46.6	102.7	46.6	M	V	L1	Yes	CM	4
2   Clermont Carr	Louth	95.2	46.7	97.0	32.4	98.8	32.9	93.6	32.6	M	V	L1	Yes	CM	4
3   Holywell Hill	Donegal	89.2	33.5	91.4	33.5	98.8	34.0	93.6	33.7	M	H	L2	Yes	CM	6
4   Kippure	Wicklow	89.1	46.9	91.3	46.9	98.7	47.0	93.5	47.0	M	V	L1	Yes	CM	4
5   Maghera	Clare	88.8	50.6	91.0	50.8	98.4	50.7	93.2	50.7	M	V	L1	Yes	CM	4
6   Mt Leinster	Carlow	89.6	51.8	91.8	52.2	99.2	52.2	94.0	51.9	M	V	L1	Yes	CM	4
7   Mullaghanish	Cork	90.0	51.8	92.2	51.8	99.6	51.8	94.4	51.8	M	V	L1	Yes	CM	4
8   Spur Hill	Cork	89.9	35.9	91.4	35.9	98.8	36.0	93.6	35.9	M	V	L2	Yes	CM	4
9   Three Rock	Dublin	88.5	36.0	90.7	35.4	96.7	35.9	92.5	35.5	M	V	L1	Yes	CM	4
10   Truskmore	Sligo	88.2	51.0	90.4	51.0	97.8	51.0	92.6	51.0	M	V	L2	Yes	CM	4
11   Castlebar	Mayo	89.3	36.0	91.5	35.7	98.9	36.1	93.7	36.0	PT	V		No	CM	4
12   Glomel	Waterford	88.3	29.9	90.5	29.9	97.9	29.9	92.7	29.9	PT	V		No	CM	6
13   Croc an Or	Kerry	89.2	16.4	91.4	16.4	98.8	16.4	93.6	16.4	PT	V		No	CM	4
14   Crosshaven	Cork	88.2	33.8	90.4	33.8	97.8	33.7	92.6	33.7	PT	V		No	CM	6
15   Dungarvan	Waterford	88.5	34.8	90.7	34.8	98.1	34.8	92.9	34.8	PT	V		Yes	CM	6
16   Gallowes Hill	Waterford	88.3	17.5	90.5	17.5	97.9	17.5	92.7	17.5	PT	V		No	CM	6
17   Greystones	Wicklow	89.5	28.4	91.7	28.4	99.1	28.4	93.9	28.4	PT	V		No	CM	6
18   Kiltuff	Tipperary	90.2	33.0							PT	V		Yes	CM	4
19   Knockmoyle	Kerry	88.4	30.0	90.6	30.0	98.0	30.0	92.8	30.0	PT	V		Yes	CM	6
20   Monaghan	Monaghan	88.9	32.9	91.1	32.7	98.5	33.1	93.3	33.0	PT	V		No	CM	6
21   Suir Valley	Kilkenny	89.0	34.2	91.2	34.2	98.6	34.2	93.4	34.2	PT	V		Yes	CM	6
22   Woodcock Hill	Clare	89.4	33.6	91.6	33.6	99.0	33.6	93.8	33.6	PR	V	L1	Yes	CM	4
23   Achill	Mayo	89.9	36.4	92.1	36.3	99.2	36.4	94.3	35.9	T	V		Yes	CM	8
24   Aranmore	Donegal	89.6	32.9	91.8	33.3	99.2	33.9	94.0	33.7	T	V		Yes	CM	8
25   Athlone	Westmeath	89.9	16.2	92.1	16.2					T	V		No	CM	8
26   Ballyhoney	Donegal	89.7	34.2	91.9	34.1	99.3	34.2	91.9	34.1	T	V		No	CM	8
27   Ballyavid	Kerry	89.1	19.4	91.3	18.9	98.7	18.7	93.5	18.4	T	V		No	CM	8
28   Bantry	Cork	88.7	33.8	90.9	33.8	98.3	35.1	93.1	33.9	T	V		No	CM	8
29   Casta	Galway	88.4	34.7	90.6	34.9	98.0	34.2	92.8	34.8	T	V		Yes	CM	8
30   Castletownbere	Cork	88.3	34.8	90.5	34.8	97.9	34.8	92.7	34.8	T	V		Yes	CM	8
31   Clifden	Galway	89.5	31.0	91.7	30.8	99.1	31.0	93.9	31.0	T	V		Yes	CM	8
32   Collins Barracks	Cork	89.7	17.7	92.0	17.4	99.3	17.1	94.1	16.5	T	V		No	CM	8
33   Fanad	Donegal	89.8	37.1	92.0	37.1	99.4	36.8	94.2	36.8	T	V		Yes	CM	8
34   Fermoy	Cork	89.4	20.6	91.6	20.6	99.0	20.6	93.8	20.6	T	V		No	CM	8
35   Killeavragh	Kerry	89.5	34.8	91.7	34.8	99.1	34.8	93.9	34.8	T	V		No	CM	8
36   Kinsale	Cork	89.0	14.3	91.2	14.3	98.6	14.0	93.4	14.0	T	V		No	CM	8
37   Leihinch	Clare	89.7	16.1	91.9	16.1	99.3	16.1	94.1	16.4	T	V		No	CM	8
38   Maamclassach	Kerry	88.7	19.9	91.1	19.9	98.3	20.2	93.1	19.9	T	V		No	CM	8
39   Magheraroarty	Donegal	88.8	20.2	91.0	20.4	98.4	20.2	93.2	20.4	T	V		No	CM	8
40   Malin	Donegal	88.9	34.2	91.1	34.3	98.5	34.6	93.3	34.1	T	V		Yes	CM	8
41   Mitchelstown	Limerick	88.6	21.9	90.8	21.9	98.2	23.7	93.0	21.9	T	V		No	CM	8
42   Moville	Donegal	88.3	34.0	90.4	34.2	97.9	34.2	92.7	34.2	T	V		Yes	CM	8
1   Cookstown Court	Dublin												Yes	CM	4
2   Donnycrook	Dublin												Yes	CM	4
3   Ballinacorney	Leitrim												No	CM	4
4   Castletown	Limerick												No	CM	4
5   Coolderry	Roscommon												No	CM	4
6   Mohercrom	Cavan												No	CM	4
7   Skreen	Meath												No	CM	4
8   Kiltorrey	Cork												No	CM	4
9   Crissard	Laois												No	CM	4
10   Barravakeen	Waterford												No	CM	4

**TABLE 2 - Points of Contact**

**Fault Response**

Service Providers Network Monitoring Centre (NMC)

Tel 1: 01 208 2259  
 Tel 2: 01 208 2685  
 Mob: 087 2423310  
 E-mail: nmc@2rn.ie

**Escalation Process**

The Service Provider

Service Provider

NMC Manager: David Mathews      Tel: 01 208 3095  
 Mob: 087 2940883  
 E-mail: dave.matthews@2rn.ie

Operations Manager: Ronan Dempsey  
 Mob: 087 9853655  
 E-mail: ronan.dempsey@2rn.ie

Executive Director: Mick Kehoe      Tel: 01 208 2249  
 Mob: 086 813 5979  
 E-mail: mick.kehoe@2rn.ie

Client

Head of Transmission:      Tel:  
 E-mail:

Head of Operations:      Tel:  
 E-mail:

Managing Director TV:      Tel:  
 E-mail:

**Routine Meetings**

Client Representative:      Name:  
 Tel:  
 Mob:  
 E-mail:

Service Provider Representative:      Name: John Clarke  
 Tel: 01 208 2858  
 Mob: 087 224 2009  
 E-mail: john.clarke@2rn.ie

## **SERVICE SCHEDULE 301**

### **Analogue FM Radio Network Access Transmitter Co-location, Power & Backup Power Supply and Access to Antenna Systems**

#### **INDEX**

- 1. Scope & Objectives**
- 2. Specific Terms and Conditions**
- 3. Service Delivery Requirements**
- 4. Broadcast System Parameters**
- 5. System Operation**
- 6. Coverage**
- 7. Standby Electrical Power**
- 8. Service Availability and Service Credits**
- 9. Sample Reports**
- 10. Reference Documents**
- 11. Abbreviations**

**Table 1 List of Sites, Locations and Transmission Site Parameters.**

**Table 2 Points Of Contact.**

## 1.0 Scope & Objective

1.1. The provision by the Service Provider 24 hours a day, during each day of each year of the Agreement of an analogue terrestrial FM radio Network Access Broadcast service consisting of provision of the following elements:

- Transmitter Collocation Space
- Power and Backup Supply
- Access to FM antenna system
- Antenna Hosting

Subject to the provisions of Clause 24 (force majeure) of the Agreement, the Service provided by the Service Provider shall be in compliance with the standards and requirements as set out in this Appendix.

## 2.0 Specific Terms and Conditions

### 2.1 Initial Term

The provision of the Service is subject to an Initial Term of 10 years (*subject to Client broadcast licence*). Prior to the expiry of the Initial Term, the Parties may agree to extend the Initial Term by a further period of 5 years. Prior to the expiry of the Term, the Parties may agree to extend the Term for successive terms of five years.

2.2 Upon Termination of the Agreement, the Parties agree that a Termination Sum will be payable by the Client as follows:

- (i) in the event the Termination Date is prior to the fifth anniversary of the date of this Agreement, as of the Termination Date, the sum of all future Tariff payments, based upon the most recent Tariff Model as of that date (where the operating charge component of the Tariff will be calculated using the most recent operating charge invoiced to the Client prior to the Termination Date), that would have been payable by the Client from the Termination Date to the fifth anniversary of the date of this Agreement including any Tariff payments due but not yet paid, together with an amount equal to the Tariff payable in the 18 month period immediately preceding the Termination Date; or
- (ii) in the event the Termination Date is on or after the fifth anniversary of the date of this Agreement the Termination Sum shall be calculated as follows:

#### ***Termination Date***

#### ***Termination Sum***

On or after fifth anniversary of the Agreement but before the sixth anniversary

100 per cent of the Tariff payments payable in the preceding 18 month period

On or after sixth anniversary of the Agreement but before the seventh anniversary

100 per cent of the Tariff payments payable in the preceding 16 month period

On or after seventh anniversary of the Agreement but before the eight anniversary

100 per cent of the Tariff payments payable in the preceding 14 month period

On or after eighth anniversary of the Agreement but before the ninth anniversary

100 per cent of the Tariff payments payable in the preceding 12 month period

In the case of Network Access the Tariff figure used in the calculation of the Termination sum shall not include that element of the charge levied in respect of other services, such as antennae hosting.

- 2.3 The provision of the Service is conditional upon the Client providing security to the value of the Termination Sum.

### 3.0 Service Delivery Requirements

- 3.1 The Service Provider shall deliver a service that meets the following minimum service delivery requirements:

Service Availability Target at each site: Operating at, or within, the Upper and Lower Failure Thresholds for 99.8% of the time. Excluding any Non-Ranking Events as specified in Section 8.

Availability measured over: Each quarterly calendar period

Upper Failure Threshold: > Normal Operating Antenna Gain Gain + 1dB

Lower Failure Threshold: < Normal Operating Antenna Gain Gain - 3dB

ERP = Effective Radiated Power

On Sites where the Client does not combine into the Service Provider's Broadcast antenna system the only measurable Availability Target will relate to Electrical Power.

- 3.2 The Service Provider shall radiate the Transmitter output power agreed with the Client. The Service shall be delivered utilising a defined antenna pattern that shall ensure that network and international interference are minimised and any restrictions are complied with in so far as is reasonably possible.

#### 4.0 Broadcast System Parameters

Subject to Clause 3 (Term) of the Agreement, the Service Provider will provide the Service at the locations listed in Table 1 in accordance with the roll-out schedule detailed in Appendix C (*Roll Out*).

#### 5.0 System Operation

##### 5.1 Transmission

At main transmission sites each antenna is constructed in two halves and each half has its own feeder cable. The overarching design criterion is that the antenna can facilitate full power into either half.

The outputs from the active transmitters are combined and the power split across the two halves of the antenna.

The Client will provide the Services Provider with an appropriate service monitoring and control interfaces (which can be integrated into the Service Providers SCADA system) at the input to the antenna system.

An overview of the arrangement for main sites can be seen in Figure 5.1.1.

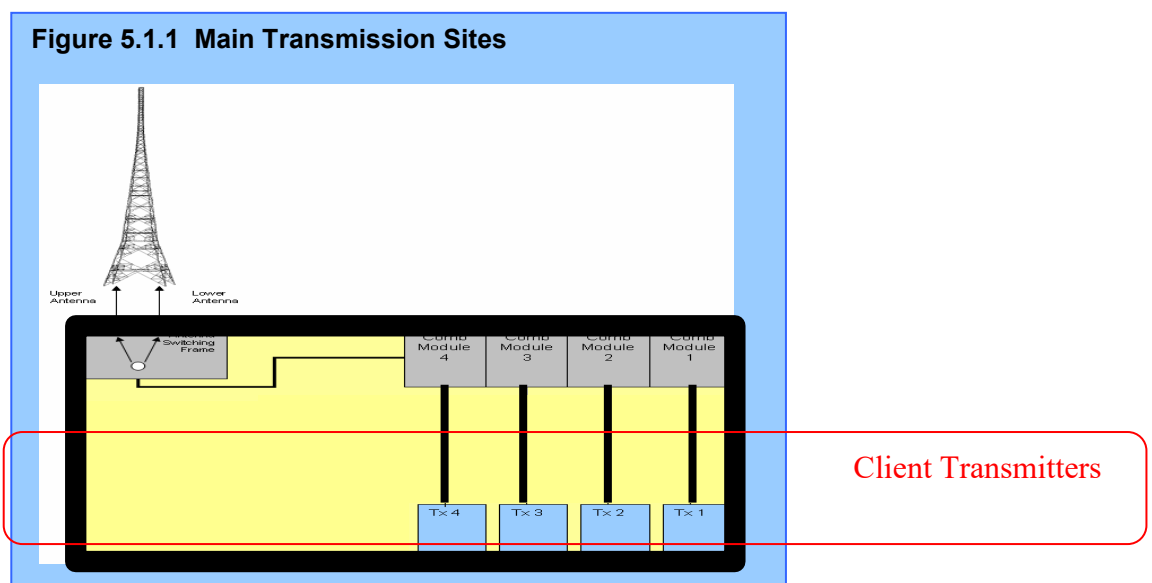

##### 5.2 Network Monitoring Centre (NMC)

The Service Provider operates a Network Monitoring Centre (NMC) in which the status and control of all elements of network infrastructure relevant to this agreement are monitored. The NMC provide a staffed point of contact (contact details in Table 2) through which all enquiries and fault notices and other reports are channelled and logged, during NMC staffed hours. Each week of the year, depending on operational demands, the NMC is staffed during the period 07:00 to 23:00 from Monday to Friday inclusive, and 08:00 to 22:00 on Saturday and Sunday. Outside of NMC staffed hours calls and enquiries are registered or recorded electronically for attention next day.

All relevant enquiries, fault notices, or other reports conveyed by telephone, email, or otherwise, to the Service Provider are logged on a fault database.

Every relevant fault incident identified by, or reported to, the NMC, including those from the Service Provider staff, are given a unique call reference number and the logging process captures all the relevant details pertinent to the call. The logging system is used as the basis for tracking faults to resolution, and generation of reports.

Details logged shall include the following:

- Name of the caller (if applicable)
- Date and time
- Transmission site location (if known)
- Contact number (if applicable)
- Service affected
- Description of the nature of the fault

5.2.1 Subject to Clause 3 (Term), the Client may from time to time require the Service Provider to investigate documented generalised complaints concerning the Client's coverage/signal strength in areas where adequate coverage is predicted by the Service Provider.

5.2.1.1 The Service Provider will be entitled to levy additional fees for such work, where such work is not covered by a pre-existing obligation under this Agreement and where the investigation proves that coverage/signal strength is as predicted. The Service Provider will conduct two investigations (maximum of three man days each) per Audio Transport Stream per year without levying additional fees.

5.2.1.2 The Service Provider will not be entitled to levy additional fees for such work, where such work is covered by a pre-existing obligation under this Agreement and where the investigation proves that coverage/signal strength is not as predicted. The Client may be entitled to a Service Credit under Section 11 in this situation.

### 5.3 Fault Response

During the staffed hours of the NMC, the NMC shall undertake an initial investigation and where appropriate ask the engineer(s) at work or on-call to verify the existence of a fault. Once a fault has been identified, it is addressed and processed in line with the procedure outlined above.

Outside of the engineer's normal working hours, if necessary the NMC will alert the on-call engineer(s) to attend the fault(s). Outside the staffed hours of the NMC the scheduled on-call engineer will be alerted to all relevant alarms raised by the Service Providers SCADA / automated alarm system.

Where the Service Provider attends a Client reported fault which subsequently is found to result from defects, faults or failures in the equipment or services provided or operated by, or on behalf of, the Client, then the Service Provider shall be entitled to levy additional fees for such work at a daily Engineering rate.

### 5.4 Routine Meetings

A general review meeting will be held every 12 months between Authorised Representatives from the Client and the Service Provider (Authorised Representatives will be identified by the Client and the Service Provider in Table 2). The function of these meetings will be to:

- To review the System performance in the previous period.
- To discuss and resolve any outstanding issues arising.
- To address any upcoming requirements.
- Update personnel/contact changes or other changes in Appendices A, B and C

#### 5.5 Documentation – records.

The Service Provider shall make sure that it keeps accurate, complete and up to date records for the term of this Agreement and for 3 years after its expiry or termination.

The Service Provider shall retain the information required to evidence compliance with its obligations under this Agreement.

#### 5.6 Maintenance

Routine preventative maintenance will be undertaken primarily during normal working hours. This will particularly be the case for antenna maintenance for Health & Safety reasons. All reasonable efforts will be made to ensure minimal interruptions and the Client, and/or any Authorised Representative nominated by the Client, will be given 5 days’ notice of any work which may have a direct impact on the Clients service. Notification of service effecting outages or power reductions (to a level below the Lower Failure Threshold) shall be issued with a minimum notice period of 5 calendar days using the Outage Notification Form in section 9.2. The works as described in Outage Notification Form shall proceed as outlined unless commented upon by the Client within 2 calendar days of the Outage Notification Form being issued.

Masts, antenna, combiners and other common equipment are used for more than one client. Where agreement cannot be reached with all clients in relation to power reductions (to a level below the Lower Failure Threshold) or outages the Service Provider reserves the right for the Service Provider Executive Director to adjudicate.

For antenna system maintenance, where possible, maintenance will be undertaken by switching to a reserve antenna, where available, or to “half stack” operation. Where this is not possible, interruptions to the transmission will be kept to a minimum and agreed in advance.

### 6.0 Coverage

6.1 Coverage is not guaranteed. The Table in Section 8 of the Agreement indicates the percentage of population covered from each transmission site. The coverage figures are generated using ATDI coverage modelling software input with the best available information.

Site Information:	Location, Height, etc.
System Parameters:	ERP, Antenna Patterns, etc.
Landscape:	Geographical, Topological, Population, Clutter, etc.

### 7.0 Standby Electrical Power

7.1 All sites with backup generators are identified in Table 1. These sites are fitted with generators that automatically start-up and provide electrical power in the event that the

electrical mains fail. A short interruption to services is experienced at mains failure and mains restore to facilitate source switching.

- 7.2 As a minimum, each generator shall have sufficient fuel capacity available on site to run continuously for a period of three days.

## **8.0 Service Availability and Service Credits**

### **8.1 Introduction**

The FM Broadcast System is designed, installed and operated to provide viewers/listeners, the population, with the highest availability that can be cost-effectively, and efficiently, obtained. Delivering the Client's Audio Transport Stream to the population is the purpose of the FM Broadcast System and therefore Service Availability is measured in terms of, and directly linked to, the population covered by each Site. Similarly Service Credits are also linked to each Site and the population it covers.

### **8.2 Service Availability Target**

The Service Availability Target for each Site is that it operates at, or within, the Upper and Lower Failure Thresholds for 99.8% of the time, as specified in Appendix A, excluding Non-Ranking Events, as specified in Section 8.3 below.

### **8.3 Non-Ranking Events**

The following Non-Ranking Events are necessary for the operation and maintenance of the FM Service, or are outside the Service Provider's reasonable control:-

- 8.3.1 A failure or interruption resulting from the Client's, and/or any Authorised Representative nominated by the Client, refusal to permit such work on any Equipment as the Service Provider reasonably regards as essential;
- 8.3.2 Where resulting from the Service Provider's due compliance with safe working practices stipulated by a Competent Authority or any other health, safety, environmental or other law or generally recognised protocol or standard (whether or not having the force of law);
- 8.3.3 Impairment of the quality of the Audio Transport Stream transmitted directly to the viewer due to anomalous propagation conditions;
- 8.3.4 Any fault requiring mast ascent during the hours of darkness or severe inclement weather where, in reasonable judgement of the Service Provider, a potential safety hazard exists;
- 8.3.5 Any breach of this Agreement by the Client, and/or any Authorised Representative nominated by the Client;
- 8.3.6 Any interruption (other than as a result of a breach by the Service Provider) as a result of:
  - 8.3.6.1 The Service Provider complying with a direction from any Competent Authority under the Licences, or from any court of competent jurisdiction requiring the Service Provider or Client, and/or any Authorised Representative nominated by the Client, to cease or suspend transmission, or;

- 8.3.6.2 The Client, and/or any Authorised Representative nominated by the Client, complying with a direction from any Competent Authority to suspend broadcasting;
- 8.3.7 Any interruption as a result of an engineering test transmission made at the request of the Client, and/or any Authorised Representative nominated by the Client, where the potential effects of the test have been previously discussed by the Client, and/or any Authorised Representative nominated by the Client, and the Service Provider;
- 8.3.8 Any fault requiring attendance at a Site during any period where such attendance is not permitted or is otherwise prevented as a consequence of a security alert or any other Force Majeure event or where the Service Provider is not allowed full and immediate access;
- 8.3.9 Any maintenance work undertaken by the Service Provider pursuant to Section 7;
- 8.3.10 Failure by the Client, and/or any Authorised Representative nominated by the Client, to deliver a valid signal;
- 8.3.11 Any Force Majeure event as contemplated by Clause 23 of the Agreement;
- 8.3.12 A reduction in nominal ERP to a level not below the Lower Failure Threshold for operational or maintenance works.
- 8.3.13 An outage or reduction in nominal ERP to a level below the Lower Failure Threshold where the Client, and/or any Authorised Representative nominated by the Client, is given prior notice and the Client, and/or any Authorised Representative nominated by the Client, do not raise an objection;
- 8.3.14 Interruptions to the System for up to 60 seconds;
- 8.3.15 Electrical supply failures excepting sites where backup generation is present as per Table 1 of this Appendix A;
- 8.3.16 Any interruption resulting from defects or failures in the equipment or services provided or operated by, or on behalf of, the Client, and/or any Authorised Representative nominated by the Client, (other than equipment which the Service Provider is required to operate and maintain under this specific Agreement);
- 8.3.17 The Service Provider undertaking any other major works, such as a mast or antenna system replacement, where the outages and / or power reductions are necessary and have been requested and agreed in advance by the Client, and/or any Authorised Representative nominated by the Client.
- 8.3.18 Any service or power reduction undertaken as specified in Clause 5.4 of the Agreement.

## 8.4 Service Credits

8.4.1 At the end of each calendar quarter the Service Provider shall calculate for each Site the total amount of time, if any, that the FM Service did not meet the Service Availability Target, as specified in Section 3 above.

8.4.2 When the actual time of service availability over the calendar quarter is less than the Service Availability Target the following formula shall be applied to calculate the Service Credit that is Payable to the Client:

Service Credit Payable =  $C \times P \times D$  where:

C = the per minute Charge/Tariff for the Service(s) at all Sites for the period;

P = the weighted population coverage percentage for each Site (including any dependants) as set out in the table below. Colum labelled 'Weighted % for Service Credit calculations';

D = the number of minutes that the Site was below the Service Availability Target in the quarter.

***Example:*** the Access FM service at Truskmore has operated outside of the failure thresholds, and below the Service Availability Target, for a period of 45 minutes;

The Service Credits will therefore be based on the following:

C = €0.38	(Per minute, based on their Access tarrif of €0.200m. €0.200m /minutes in year).
P = 8.041%	(Truskmore based on table below).
D = 45	(minutes)

$$\begin{aligned}
 \text{Truskmore Credit Payable} &= C \times P \times D \\
 &= 0.38 \times 0.08041 \times 45 \\
 \text{Total} &= €1.37
 \end{aligned}$$

8.4.2.1 For the avoidance of doubt, the amount used for C in the above formula shall be from the Tariff Model for the year in which the quarter falls.

8.4.2.2 The Service Provider shall notify the Client, and/or any Authorised Representative nominated by the Client, of the period, nature and timing of all faults at each Site.

SITES		COUNTY		
			Best Server Coverage: Indoor (% Households)	Weighted % for Service Credit calculations
1	<b>Cairn Hill</b>	Longford	3.910	8.429
2	<b>Clermont Carn</b>	Louth	4.950	10.670
3	<b>Maghera</b>	Clare	8.820	19.013
4	<b>Mt Leinster</b>	Carlow	10.460	22.548
5	<b>Mullaghanish</b>	Cork	6.040	13.020
6	<b>Truskmore</b>	Sligo	3.730	8.041
6	<b>Castlebar</b>	Mayo	0.660	1.423
7	<b>Clonmel</b>	Waterford	0.710	1.531
7	<b>Holywell Hill</b>	Donegal	0.840	1.811
8	<b>Knockmoyle</b>	Kerry	1.310	2.824
8	<b>Monaghan</b>	Monaghan	1.010	2.177
9	<b>Woodcock Hill</b>	Clare	3.240	6.984
9	<b>Achill</b>	Mayo	0.180	0.388
10	<b>Clifden</b>	Galway	0.190	0.410
10	<b>Fanad</b>	Donegal	0.080	0.172
11	<b>Fermoy</b>	Cork	0.260	0.560
		<b>TOTALS =</b>	<b>46.39</b>	<b>100.00</b>

## 9.0 Sample Reports

### 9.1 Sample Outage Report:



**Transmission Outage Report**

**Reference Number:**

**Date:**

**Service(s):**

**Transmission Site(s):**

**Time / Duration of Outage:**

**Report Compiled By:**

**Fault / Outage Summary:**

**Notifications:**

**Details Of Cause & Remedial Actions:**

9.2 Sample Outage Notification Form



**Transmission Outage Notification Form**

**Reference Number:**

**Date:**

**Service(s):**

**Transmission Site(s):**

**Time / Duration of Outage:**

**Details:**

### 9.3 Sample Availability Report

Monthly Service Availability Figures (Including Electricity Supply Outages)														
2009		Jan	Feb	Mar	Apr	May	Jun	Jul	Aug	Sep	Oct	Nov	Dec	Year
ATT	RTÉ One	99.9924	99.9999	99.9999	99.9999	99.9999	99.9999	99.9999	99.9999	99.9999	99.9999	99.9999	99.9999	99.9993
	RTÉ Two	99.9999	99.9916	99.9999	99.9999	99.9999	99.9999	99.9999	99.9999	99.9999	99.9999	99.9999	99.9999	99.9992
	TV3	99.9999	99.9999	99.9841	99.9999	99.9999	99.9999	99.9999	99.9999	99.9999	99.9999	99.9999	99.9999	99.9986
	TG4	99.9999	99.9999	99.9999	99.3284	99.9999	99.9999	99.9999	99.9999	99.9999	99.9999	99.9999	99.9999	99.9439
DTT	Mux 1				99.9999	99.9999	99.2358	99.9999	99.9999	99.9999	99.9999	99.9999	99.9999	99.9150
	Mux 2				99.9999	99.9999	99.9999	99.8654	99.9999	99.9999	99.9999	99.9999	99.9999	99.9650
	Mux 3				99.9999	99.9999	99.9999	99.9999	99.9756	99.9999	99.9999	99.9999	99.9999	99.9972
	Mux 4				99.9999	99.9999	99.9999	99.9999	99.9999	99.9962	99.9999	99.9999	99.9999	99.9995
Radio	RTÉ Radio 1	99.9999	99.9999	99.9999	99.9999	99.9999	99.9999	99.9999	99.9999	99.9653	99.9999	99.9999	99.9999	99.9970
	RTÉ 2FM	99.9999	99.9999	99.9999	99.9999	99.9999	99.9999	99.9999	99.9999	99.9999	99.9423	99.9999	99.9999	99.9951
	RTÉ RnaG	99.9999	99.9999	99.9999	99.9999	99.9999	99.9999	99.9999	99.9999	99.9999	99.9999	99.8642	99.9999	99.9886
	RTÉ Lyric	99.9999	99.9999	99.9999	99.9999	99.9999	99.9999	99.9999	99.9999	99.9999	99.9999	99.9999	99.9756	99.9979
	Today FM	99.9999	99.9999	99.9999	99.9999	99.9999	99.9999	99.9999	99.9999	99.9999	99.9999	99.9999	99.9782	99.9981

Monthly Service Availability Figures (Excluding Electricity Supply Outages)														
2009		Jan	Feb	Mar	Apr	May	Jun	Jul	Aug	Sep	Oct	Nov	Dec	Year
ATT	RTÉ One	99.9924	99.9999	99.9999	99.9999	99.9999	99.9999	99.9999	99.9999	99.9999	99.9999	99.9999	99.9999	99.9993
	RTÉ Two	99.9999	99.9916	99.9999	99.9999	99.9999	99.9999	99.9999	99.9999	99.9999	99.9999	99.9999	99.9999	99.9992
	TV3	99.9999	99.9999	99.9841	99.9999	99.9999	99.9999	99.9999	99.9999	99.9999	99.9999	99.9999	99.9999	99.9986
	TG4	99.9999	99.9999	99.9999	99.3284	99.9999	99.9999	99.9999	99.9999	99.9999	99.9999	99.9999	99.9999	99.9439
DTT	Mux 1				99.9999	99.9999	99.2358	99.9999	99.9999	99.9999	99.9999	99.9999	99.9999	99.9150
	Mux 2				99.9999	99.9999	99.9999	99.8654	99.9999	99.9999	99.9999	99.9999	99.9999	99.9650
	Mux 3				99.9999	99.9999	99.9999	99.9999	99.9756	99.9999	99.9999	99.9999	99.9999	99.9972
	Mux 4				99.9999	99.9999	99.9999	99.9999	99.9999	99.9962	99.9999	99.9999	99.9999	99.9995
Radio	RTÉ Radio 1	99.9999	99.9999	99.9999	99.9999	99.9999	99.9999	99.9999	99.9999	99.9653	99.9999	99.9999	99.9999	99.9970
	RTÉ 2FM	99.9999	99.9999	99.9999	99.9999	99.9999	99.9999	99.9999	99.9999	99.9999	99.9423	99.9999	99.9999	99.9951
	RTÉ RnaG	99.9999	99.9999	99.9999	99.9999	99.9999	99.9999	99.9999	99.9999	99.9999	99.9999	99.8642	99.9999	99.9886
	RTÉ Lyric	99.9999	99.9999	99.9999	99.9999	99.9999	99.9999	99.9999	99.9999	99.9999	99.9999	99.9999	99.9756	99.9979
	Today FM	99.9999	99.9999	99.9999	99.9999	99.9999	99.9999	99.9999	99.9999	99.9999	99.9999	99.9999	99.9782	99.9981

## 10.0 Reference Documents

ITU-R Rec 647 or S/PDIF	AES/EBU Signal Format.
ITU-T Rec J.41	Companded Mode resolution.
ITU-T Rec J.17	Pre/De-Emphasis.
DIN 45 403	Intermodulation.
CCIR Rec 468-4	"Measurement of Audio frequency noise voltage levels in Sound Broadcasting. "
CCIR Rec 450-1	"Transmission Standards for FM Sound Broadcasting at VHF."
ETS 300 384(CCIR Rec 450)	VHF FM Sound Broadcasting Transmitters.

## 11.0 Abbreviations

ATDI	Advanced Topographic Development & Images Limited
ASI	Asynchronous Serial Interface
BAI	Broadcasting Authority of Ireland
FM	Frequency Modulated
MHEG	Multimedia and Hypermedia Experts Group
NMC	Network Monitoring Centre
RDS	Radio Data System
SCADA	Supervisory Control and Data Acquisition
STM-1	Synchronous Transport Module - a microwave radio circuit
VHF	Very High Frequency

**FM TABLE 1 Site Data**

SITES	COUNTY	Example Service					Details		
		Availing of Collocation space for Transmitters	Availing of 2rn Electrical Infrastructure	Combined into 2rn Broadcast antenna	Availing of Antenna Hosting	Distribution Service Presentation	Antenna Polarity H = Horizontal V = Vertical	Back up Electrical Generator Available	2Stack Antenna
1 Cairn Hill	Longford	Yes	Yes	Yes	Yes	Yes	V	Yes	Yes
2 Maghera	Clare	Yes	Yes	Yes	Yes	Yes	V	Yes	Yes
3 Mt Leinster	Carlow	Yes	Yes	No	Yes	Yes	N/A	Yes	N/A
4 Mullaghanish	Cork	Yes	Yes	Yes	Yes	Yes	V	Yes	Yes
5 Truskmore	Sligo	Yes	Yes	Yes	Yes	Yes	V	Yes	Yes
6 Clonmel	Waterford	Yes	Yes	No	Yes	No	N/A	No	N/A
7 Holywell Hill	Donegal	Yes	Yes	Yes	Yes	No	V	Yes	Yes
8 Knockmoyle	Kerry	Yes	Yes	Yes	Yes	No	V	Yes	Yes
9 Monaghan	Monaghan	Yes	Yes	No	Yes	No	N/A	No	N/A
10 Woodcock Hill	Clare	Yes	Yes	No	Yes	Yes	N/A	Yes	N/A
11 Fermoy	Cork	Yes	Yes	No	Yes	No	N/A	No	N/A
12 Clifden	Galway	Yes	Yes	Yes	Yes	No	N/A	Yes	Yes
13 Clermont Carn	Louth	Yes	Yes	No	Yes	Yes	N/A	Yes	N/A
14 Achill	Mayo	Yes	Yes	Yes	Yes	No	V	Yes	Yes
15 Castlebar	Mayo	Yes	Yes	Yes	Yes	No	V	No	Yes
16 Fanad	Cork	Yes	Yes	Yes	Yes	No	V	Yes	Yes

**TABLE 2 - Points of Contact**

**Fault Response**

Service Providers Network Monitoring Centre (NMC)

Tel 1: 01 208 2259  
 Tel 2: 01 208 2685  
 Mob: 087 2423310  
 E-mail: nmc@2rn.ie

**Escalation Process**

The Service Provider

NMC Manager: David Mathews

Tel: 01 208 3095  
 Mob: 087 2940883  
 E-mail: dave.matthews@2rn.ie

Operations Manager: Ronan Dempsey

Mob: 087 9863655  
 E-mail: ronan.dempsey@2rn.ie

Executive Director: Mick Kehoe

Tel: 01 208 2249  
 Mob: 086 813 5979  
 E-mail: mick.kehoe@2rn.ie

Client

Head of Transmission:

Tel:  
 E-mail:

Head of Operations:

Tel:  
 E-mail:

Managing Director TV:

Tel:  
 E-mail:

**Routine Meetings**

Client Representative:

Name:  
 Tel:  
 Mob:  
 E-mail:

Service Provider Representative:

Name: John Clarke  
 Tel: 01 208 2858  
 Mob: 087 224 2009  
 E-mail: john.clarke@2rn.ie

**SERVICE SCHEDULE 401**

**Analogue FM Radio Network Access  
Transmitter Co-location, Power & Backup Power  
Supply and Access to Antenna Systems,  
And Distribution Service**

**INDEX**

1. **Scope & Objectives**
2. **Specific Terms and Conditions**
3. **Service Delivery Requirements**
4. **Broadcast System Parameters**
5. **Signal Interface Points**
6. **Signal Specification**
7. **System Operation**
8. **Coverage**
9. **Standby Electrical Power**
10. **Service Availability and Service Credits**
11. **Sample Reports**
12. **Reference Documents**
13. **Abbreviations**

**Table 1            List of Sites, Locations and Transmission Site Parameters.**

**Table 2            Points Of Contact.**

## 1.0 Scope & Objective

1.2. The provision by the Service Provider 24 hours a day, during each day of each year of the Agreement of an analogue terrestrial FM radio Network Access Broadcast service consisting of provision of the following elements:

- Transmitter Collocation Space
- Power and Backup Supply
- Access to FM antenna system
- Antenna Hosting
- Distribution of Audio Transport Stream

Subject to the provisions of Clause 24 (force majeure) of the Agreement, the Service provided by the Service Provider shall be in compliance with the standards and requirements as set out in this Appendix.

## 2.0 Specific Terms and Conditions

### 2.1 Initial Term

The provision of the Service is subject to an Initial Term of 10 years (*subject to Client broadcast licence*). Prior to the expiry of the Initial Term, the Parties may agree to extend the Initial Term by a further period of 5 years. Prior to the expiry of the Term, the Parties may agree to extend the Term for successive terms of five years.

2.2 Upon Termination of the Agreement, the Parties agree that a Termination Sum will be payable by the Client as follows:

- (i) in the event the Termination Date is prior to the fifth anniversary of the date of this Agreement, as of the Termination Date, the sum of all future Tariff payments, based upon the most recent Tariff Model as of that date (where the operating charge component of the Tariff will be calculated using the most recent operating charge invoiced to the Client prior to the Termination Date), that would have been payable by the Client from the Termination Date to the fifth anniversary of the date of this Agreement including any Tariff payments due but not yet paid, together with an amount equal to the Tariff payable in the 18 month period immediately preceding the Termination Date; or
- (ii) in the event the Termination Date is on or after the fifth anniversary of the date of this Agreement the Termination Sum shall be calculated as follows:

<i>Termination Date</i>	<i>Termination Sum</i>
On or after fifth anniversary of the Agreement but before the sixth anniversary	100 per cent of the Tariff payments payable in the preceding 18 month period
On or after sixth anniversary of the Agreement but before the seventh anniversary	100 per cent of the Tariff payments payable in the preceding 16 month period
On or after seventh anniversary of the Agreement but before the eight	100 per cent of the Tariff payments payable in the preceding 14 month

anniversary	period
On or after eighth anniversary of the Agreement but before the ninth anniversary	100 per cent of the Tariff payments payable in the preceding 12 month period

In the case of Network Access the Tariff figure used in the calculation of the Termination sum shall not include that element of the charge levied in respect of other services, such as antennae hosting.

- 2.3 The provision of the Service is conditional upon the Client providing security to the value of the Termination Sum.

### 3.0 Service Delivery Requirements

- 3.1 The Service Provider shall deliver a service that meets the following minimum service delivery requirements:

Service Availability Target at each site:	Operating at, or within, the Upper and Lower Failure Thresholds for 99.8% of the time. Excluding any Non-Ranking Events as specified in Section 8.
Availability measured over:	Each quarterly calendar period
Upper Failure Threshold:	> Normal Operating Antenna Gain Gain + 1dB
Lower Failure Threshold:	< Normal Operating Antenna Gain Gain - 3dB

On Sites where the Client does not combine into the Service Provider's Broadcast antenna system the only measurable Availability Target will relate to Electrical Power.

- 3.2 The Service Provider shall radiate the Transmitter output power agreed with the Client. The Service shall be delivered utilising a defined antenna pattern that shall ensure that network and international interference are minimised and any restrictions are complied with in so far as is reasonably possible.

#### **4.0 Broadcast System Parameters**

- 4.1 The Client will present the agreed Audio Transport Stream at the Signal Interface Points, from which the Service Provider will accept, distribute and present it to the Client at the transmission sites listed in Table 1 attached.
- 4.2 Subject to Clause 3 (Term) of the Agreement, the Service Provider will provide the Service at the locations listed in Table 1 in accordance with the roll-out schedule detailed in Appendix C (*Roll Out*).

#### **5.0 Signal Interface Points**

- 5.1 The Client shall present two diverse and separate feeds for the Audio Transport Stream at two Signal Interface Points for distribution to the transmission sites detailed in Table 1.

The Service Provider has two Signal Interface Points at its premises at Cookstown Court in Tallaght, Dublin 24 and has a further two Signal Interface Points located adjacent to the tower on the RTÉ campus in Donnybrook Dublin 4.

#### **6.0 Signal Specification**

- 6.1 The Audio Transport Stream presented by the Client to the Service Provider at the Signal Interface Point shall be:
- Audio Left – Line level Audio (0dBu 1mW into 600Ω)
  - Audio Right - Line level Audio (0dBu 1mW into 600Ω)
  - Radio Data System (RDS) Data Stream.
  - Copper Wire Physical Interface

#### **7.0 System Operation**

The Clients Audio Transport Stream presented at the Signal Interface Points shall be transported to eleven main transmission sites via a combination of fibre optic cables and microwave radio links. At the eleven main transmission sites the Audio Transport Stream will be presented to the Client. The Client will feed the Audio Transport Stream to transmitters and produce an RF signal at the specified power. This RF signal will be presented to the Service Providers combiner system by the Client.

The Client will provide the Services Provider with an appropriate service monitoring and control interfaces (which can be integrated into the Service Providers SCADA system) at the output of the Distribution system and at the input to the antenna system.

##### **7.1 Distribution**

Each Audio Transport Stream is multiplexed with other services and distributed to the transmission sites. The Service Provider utilises interconnected equipment at Cookstown Court in Tallaght and at RTÉ in Donnybrook to achieve diverse connectivity to the microwave radio distribution system. An overview is shown in Figure 7.1.1.

**Figure 7.1.1 Distribution overview**

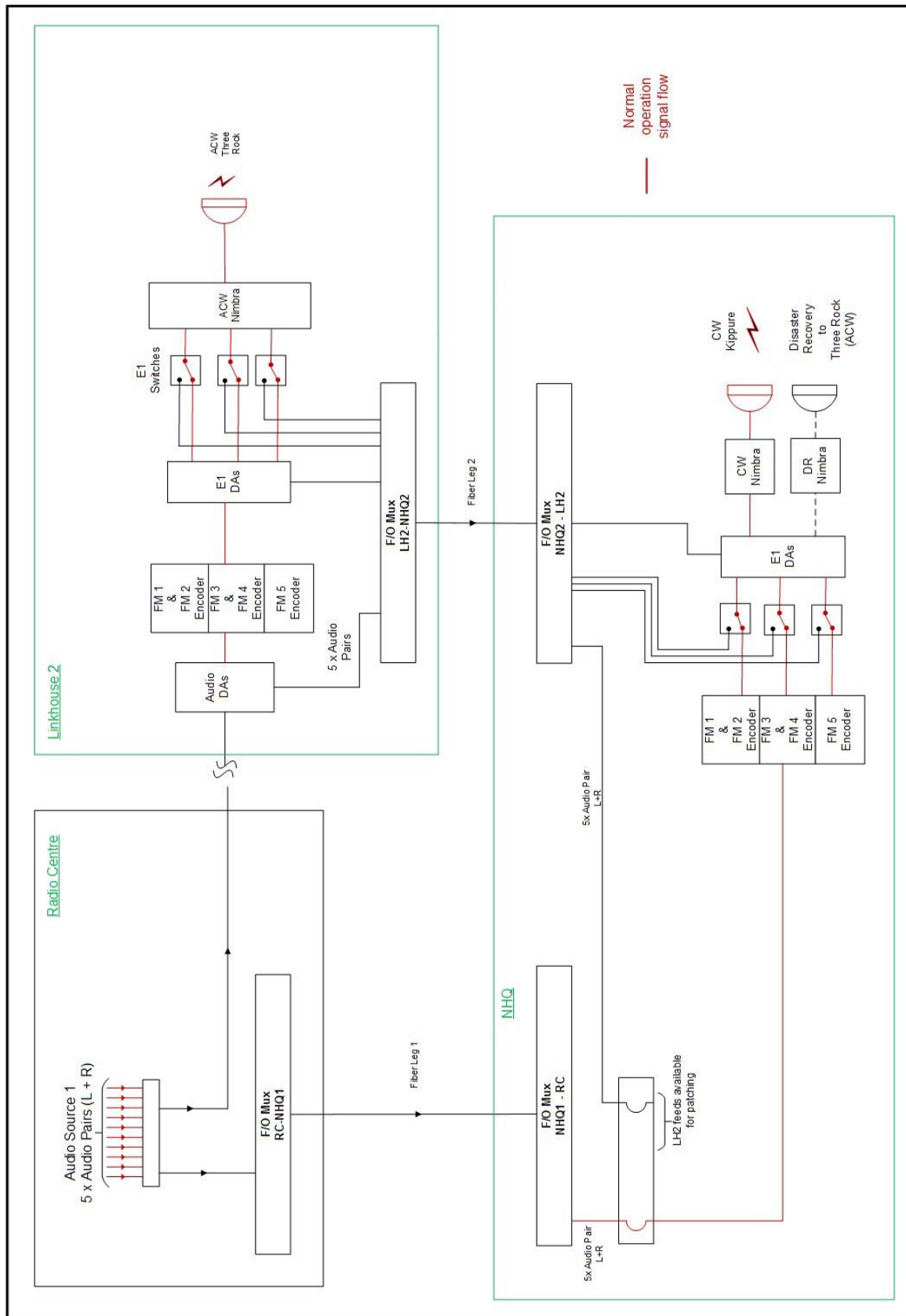

The primary distribution system consists of two STM-1 microwave radio circuits with two radial spurs. An overview of the microwave radio distribution system is shown in Figure 7.1.2. *[Please Note The Service provider is currently in the process of migrating its distribution system to a hybrid fibreoptic/fixed radio link network and this section 7.1 is subject to change.]*

**Figure 7.1.2 Distribution system overview**

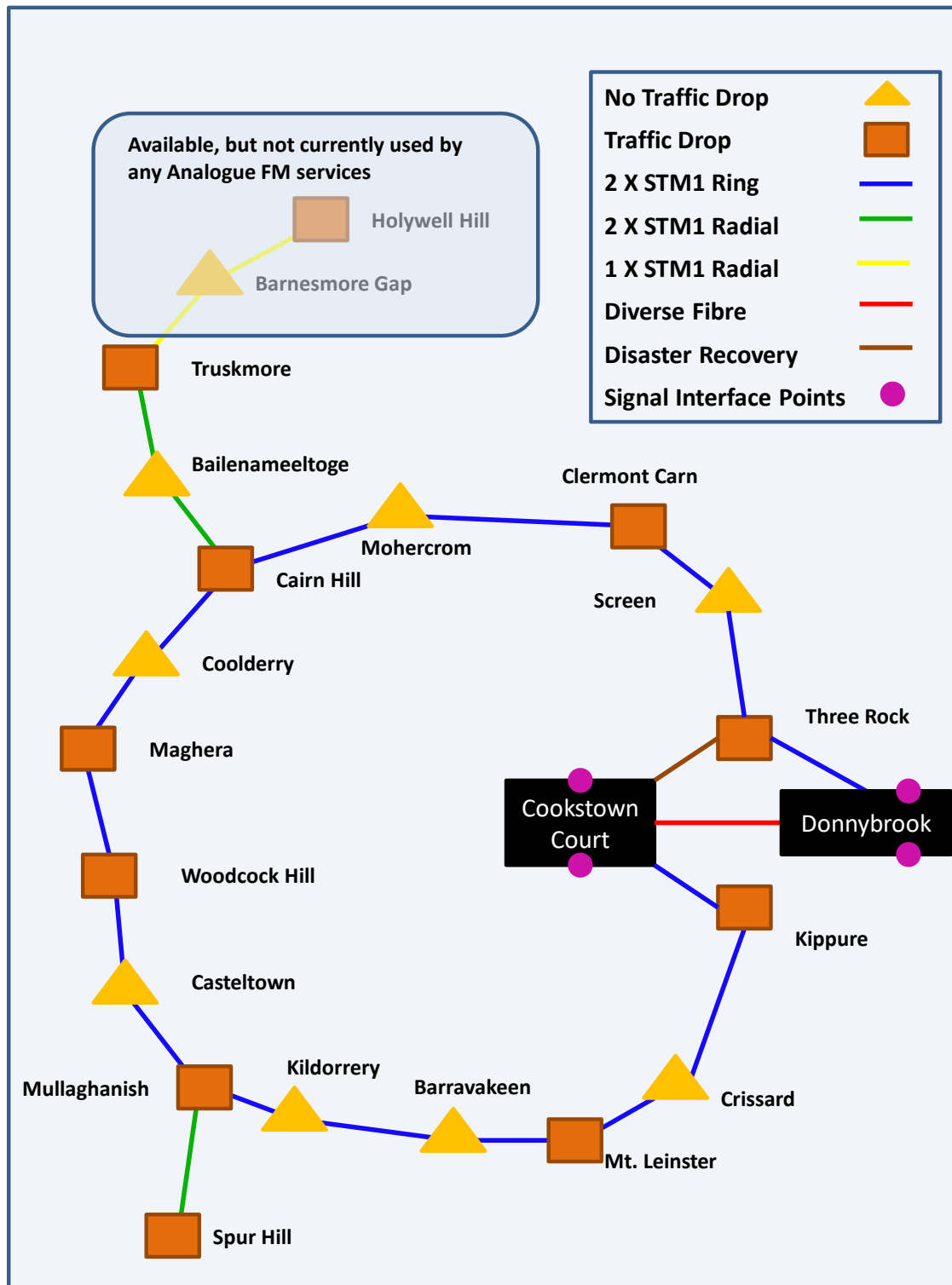

## 7.2 Transmission

At the main transmission sites the Audio Transport Stream is fed to the Clients transmitters which produce an RF signal at the specified power. The RF signal is presented to the Service Providers antenna combiner system by the Client.

At the main transmission sites each antenna is constructed in two halves and each half has its own feeder cable. The overarching design criterion is that the antenna can facilitate full power into either half.

The outputs from the active transmitters are combined and the power split across the two halves of the antenna.

An overview of the arrangement for main sites can be seen in Figure 7.2.1.

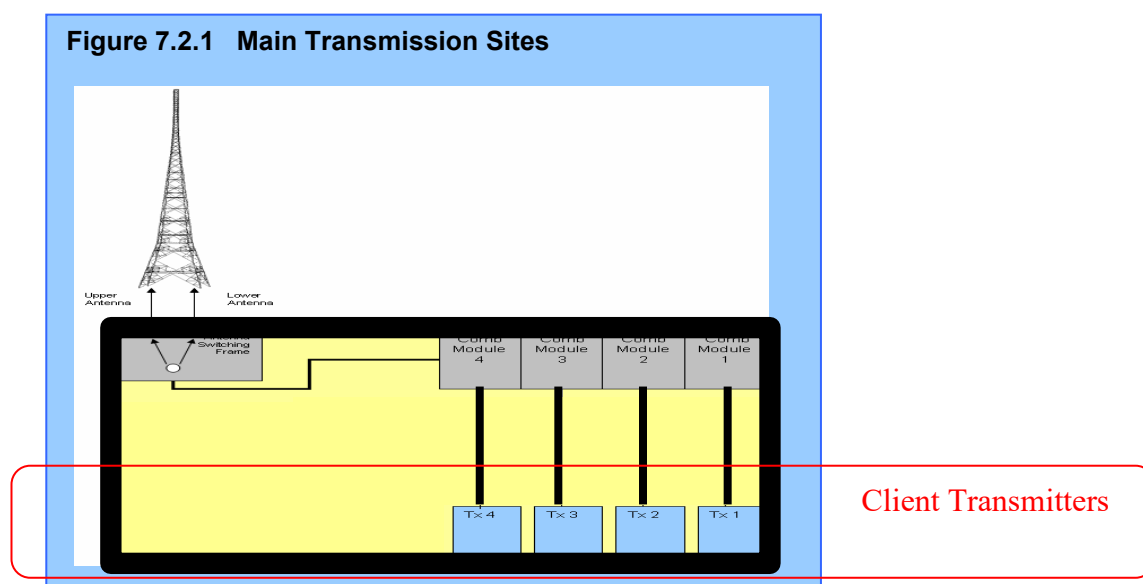

## 7.3 Network Monitoring Centre (NMC)

The Service Provider operates a Network Monitoring Centre (NMC) in which the status and control of all elements of network infrastructure relevant to this agreement are monitored. The NMC provide a staffed point of contact (contact details in Table 2) through which all enquiries and fault notices and other reports are channelled and logged, during NMC staffed hours. Each week of the year, depending on operational demands, the NMC is staffed during the period 07:00 to 23:00 from Monday to Friday inclusive, and 08:00 to 22:00 on Saturday and Sunday. Outside of NMC staffed hours calls and enquiries are registered or recorded electronically for attention next day.

All relevant enquiries, fault notices, or other reports conveyed by telephone, email, or otherwise, to the Service Provider are logged on a fault database.

Every relevant fault incident identified by, or reported to, the NMC, including those from the Service Provider staff, are given a unique call reference number and the logging process captures all the relevant details pertinent to the call. The logging system is used as the basis for tracking faults to resolution, and generation of reports.

Details logged shall include the following:

- Name of the caller (if applicable)
- Date and time
- Transmission site location (if known)
- Contact number (if applicable)
- Service affected
- Description of the nature of the fault

Subject to Clause 3 (Term), the Client may from time to time require the Service Provider to investigate documented generalised complaints concerning the Client's coverage/signal strength in areas where adequate coverage is predicted. The Service Provider shall be entitled to levy additional fees for such work, where such work is not covered by a pre-existing obligation under this Agreement.

#### 7.4 Fault Response

During the staffed hours of the NMC, the NMC shall undertake an initial investigation and where appropriate ask the engineer(s) at work or on-call to verify the existence of a fault. Once a fault has been identified, it is addressed and processed in line with the procedure outlined above.

Outside of the engineer's normal working hours, if necessary the NMC will alert the on-call engineer(s) to attend the fault(s). Outside the staffed hours of the NMC the scheduled on-call engineer will be alerted to all relevant alarms raised by the Service Providers SCADA / automated alarm system.

Where the Service Provider attends a Client reported fault which subsequently is found to result from defects, faults or failures in the equipment or services provided or operated by, or on behalf of, the Client, then the Service Provider shall be entitled to levy additional fees for such work at a daily Engineering rate.

#### 7.5 Routine Meetings

A general review meeting will be held every 12 months between Authorised Representatives from the Client and the Service Provider (Authorised Representative will be identified by the Client and the Service Provider in Table 2). The function of these meetings will be to:

- To review the System performance in the previous period.
- To discuss and resolve any outstanding issues arising.
- To address any upcoming requirements.
- Update personnel/contact changes or other changes in Appendices A, B and C.

#### 7.6 Documentation – records.

The Service Provider shall make sure that it keeps accurate, complete and up to date records for the term of this Agreement and for 3 years after its expiry or termination.

The Service Provider shall retain the information required to evidence compliance with its obligations under this Agreement.

## 7.7 Maintenance

Routine preventative maintenance will be undertaken primarily during normal working hours. This will particularly be the case for antenna maintenance for Health & Safety reasons. All reasonable efforts will be made to ensure minimal interruptions and the Client will be given 5 days' notice of any directly impacting work. Notification of service effecting outages or power reductions (to a level below the Lower Failure Threshold) shall be issued with a minimum notice period of 5 calendar days using the Outage Notification Form in section 9.2. The works as described in Outage Notification Form shall proceed as outlined unless commented upon by the Client within 2 calendar days of the Outage Notification Form being issued.

Masts, antenna, combiners and other common equipment are used for more than one client. Where agreement cannot be reached with all clients in relation to power reductions (to a level below the Lower Failure Threshold) or outages the Service Provider reserves the right for the Service Provider Executive Director to adjudicate.

For antenna system maintenance, where possible, maintenance will be undertaken by switching to a reserve antenna, where available, or to "half stack" operation. Where this is not possible, interruptions to the transmission will be kept to a minimum and agreed in advance.

## 8.0 Coverage

- 8.1 Coverage is not guaranteed. The Table in Section 8 of the Agreement indicates the percentage of population covered from each transmission site. The coverage figures are generated using ATDI coverage modelling software input with the best available information.

Site Information:	Location, Height, etc.
System Parameters:	ERP, Antenna Patterns, etc.
Landscape:	Geographical, Topological, Population, Clutter, etc.

## 9.0 Standby Electrical Power

- 9.1 All sites with backup generators are identified in Table 1. These sites are fitted with generators that automatically start-up and provide electrical power in the event that the electrical mains fail. A short interruption to services is experienced at mains failure and mains restore to facilitate source switching.
- 9.2 As a minimum, each generator shall have sufficient fuel capacity available on site to run continuously for a period of three days.

## 10 Service Availability and Service Credits

### 10.1 Introduction

The System is designed, installed and operated to provide viewers/listeners, the population, with the highest availability that can be cost-effectively, and efficiently, obtained. Delivering the Client's Audio Transport Stream to the population is the purpose of the System and therefore Service Availability is measured in terms of, and directly

linked to, the population covered by each Site. Similarly Service Credits are also linked to each Site and the population it covers.

## 10.2 Service Availability Target

10.2.1 The Service Availability Target for each Site is that it operates at, or within, the Upper and Lower Failure Thresholds for 99.8% of the time, as specified in Appendix A, excluding Non-Ranking Events, as specified in Section 10.3 below.

## 10.3 Non-Ranking Events

The following Non-Ranking Events are necessary for the operation and maintenance of the Service, or are outside the Service Provider's reasonable control:-

- 10.3.1 A failure or interruption resulting from the Client's, and/or any Authorised Representative nominated by the Client, refusal to permit such work on any Equipment as the Service Provider reasonably regards as essential;
- 10.3.2 Where resulting from the Service Provider's due compliance with safe working practices stipulated by a Competent Authority or any other health, safety, environmental or other law or generally recognised protocol or standard (whether or not having the force of law);
- 10.3.3 Impairment of the quality of the Audio Transport Stream transmitted directly to the viewer due to anomalous propagation conditions;
- 10.3.4 Any fault requiring mast ascent during the hours of darkness or severe inclement weather where, in reasonable judgement of the Service Provider, a potential safety hazard exists;
- 10.3.5 Any breach of this Agreement by the Client, and/or any Authorised Representative nominated by the Client;
- 10.3.6 Any interruption (other than as a result of a breach by the Service Provider) as a result of:
  - 10.3.6.1 The Service Provider complying with a direction from any Competent Authority under the Licences, or from any court of competent jurisdiction requiring the Service Provider or Client, and/or any Authorised Representative nominated by the Client, to cease or suspend transmission, or;
  - 10.3.6.2 The Client, and/or any Authorised Representative nominated by the Client, complying with a direction from any Competent Authority to suspend broadcasting;
- 10.3.7 Any interruption as a result of an engineering test transmission made at the request of the Client, and/or any Authorised Representative nominated by the Client, where the potential effects of the test have been previously discussed by the Client, and/or any Authorised Representative nominated by the Client, and the Service Provider;
- 10.3.8 Any fault requiring attendance at a Site during any period where such attendance is not permitted or is otherwise prevented as a consequence of a security alert or any other Force Majeure event or where the Service Provider is not allowed full and immediate access;
- 10.3.9 Any maintenance work undertaken by the Service Provider pursuant to Section 7;
- 10.3.10 Failure by the Client, and/or any Authorised Representative nominated by the Client, to deliver a valid signal to the distribution system and / or to an antenna;

- 10.3.11 Any Force Majeure event as contemplated by Clause 23 of the Agreement;
- 10.3.12 A reduction in nominal ERP to a level not below the Lower Failure Threshold for operational or maintenance works.
- 10.3.13 An outage or reduction in nominal ERP to a level below the Lower Failure Threshold where the Client, and/or any Authorised Representative nominated by the Client, is given prior notice and the Client, and/or any Authorised Representative nominated by the Client, do not raise an objection;
- 10.3.14 Interruptions to the System for up to 60 seconds;
- 10.3.15 Electrical supply failures excepting sites where backup generation is present as per Table 1 of this Appendix A;
- 10.3.16 Interruptions to the primary or secondary distribution systems as a result of anomalous propagation or interference effects, including obstructions, which are outside the Service Provider's reasonable control. The Service Provider will work with planners, developers, County Councils and any other relevant authority to monitor the possibility of obstructions occurring and will notify the Client upon becoming aware of the possibility of an obstruction;
- 10.3.17 Any interruption resulting from defects or failures in the equipment or services provided or operated by, or on behalf of, the Client, and/or any Authorised Representative nominated by the Client, (other than equipment which the Service Provider is required to operate and maintain under this specific Agreement);
- 10.3.18 The Service Provider undertaking any other major works, such as a mast or antenna system replacement, where the outages and / or power reductions are necessary and have been requested and agreed in advance by the Client, and/or any Authorised Representative nominated by the Client.
- 10.3.19 Any service or power reduction undertaken as specified in Clause 5.4 of the Agreement.

#### 10.4 Service Credits

- 10.4.1 At the end of each calendar quarter the Service Provider shall calculate for each Site the total amount of time, if any, that the FM Service did not meet the Service Availability Target, as specified in Section 3 above.
- 10.4.2 When the actual time of service availability over the calendar quarter is less than the Service Availability Target the following formula shall be applied to calculate the Service Credit that is Payable to the Client:

Service Credit Payable = C x P x D where:

- C = the per minute Charge/Tariff for the Service(s) at all Sites for the period;
- P = the weighted population coverage percentage for each Site (including any dependants) as set out in the table below. Colum labelled 'Weighted % for Service Credit calculations';
- D = the number of minutes that the Site was below the Service Availability Target in the quarter.

**Example:** the Access FM service at Truskmore has operated outside of the failure thresholds, and below the Service Availability Target, for a period of 45 minutes;

The Service Credits will therefore be based on the following:

C = €0.42 (Per minute, based on their Access tariff of €0.220m.  
€0.220m / minutes in year).  
P = 6.665% (Truskmore based on table below).  
D = 45 (minutes)

***Truskmore Credit Payable*** =  $C \times P \times D$

=  $0.42 \times 0.0665 \times 45$

Total = €1.26

- 10.4.2.1 For the avoidance of doubt, the amount used for C in the above formula shall be from the Tariff Model for the year in which the quarter falls.
- 10.4.2.2 The Service Provider shall notify the Customer of the period, nature and timing of all faults at each Site.
- 10.4.2.3 The Service Provider shall have no obligation to pay Service Credits with respect to any Site until after the Initial Installation Date in respect of such Site.

SITES		COUNTY		
			Best Server Coverage: Indoor (% Households)	Weighted % for Service Credit calculations
1	<b>Clermont Carn</b>	Louth	5.230	6.552
2	<b>Kippure</b>	Wicklow	23.040	28.865
3	<b>Maghera</b>	Clare	10.420	13.054
4	<b>Mt Leinster</b>	Carlow	10.480	13.130
5	<b>Mullaghanish</b>	Cork	6.400	8.018
6	<b>Spur Hill</b>	Cork	3.280	4.109
7	<b>Truskmore</b>	Sligo	5.320	6.665
8	<b>Castlebar</b>	Mayo	2.160	2.706
9	<b>Clonmel</b>	Waterford	0.720	0.902
10	<b>Crosshaven</b>	Cork	1.090	1.366
11	<b>Dungarvan</b>	Waterford	1.070	1.341
12	<b>Greystones</b>	Wicklow	0.720	0.902
13	<b>Holywell Hill</b>	Donegal	0.880	1.102
14	<b>Knockmoyle</b>	Kerry	1.310	1.641
15	<b>Monaghan</b>	Monaghan	1.010	1.265
16	<b>Suir Valley</b>	Kilkenny	0.540	0.677
17	<b>Woodcock Hill</b>	Clare	3.250	4.072
18	<b>Achill</b>	Mayo	0.390	0.489
19	<b>Clifden</b>	Galway	0.290	0.363
20	<b>Collins Barracks</b>	Cork	1.000	1.253
21	<b>Fanad</b>	Donegal	0.690	0.864
22	<b>Kinsale</b>	Cork	0.110	0.138
23	<b>Moville</b>	Donegal	0.420	0.526
		<b>Totals</b>	<b>79.82</b>	<b>100.00</b>

## 11 Sample Reports

### 11.1 Sample Outage Report:



**Transmission Outage Report**

**Reference Number:**

**Date:**

**Service(s):**

**Transmission Site(s):**

**Time / Duration of Outage:**

**Report Compiled By:**

**Fault / Outage Summary:**

**Notifications:**

**Details Of Cause & Remedial Actions:**



**Transmission Outage Notification Form**

**Reference Number:**

**Date:**

**Service(s):**

**Transmission Site(s):**

**Time / Duration of Outage:**

**Details:**

### 11.3 Sample Availability Report

Monthly Service Availability Figures (Including Electricity Supply Outages)

2009		Jan	Feb	Mar	Apr	May	Jun	Jul	Aug	Sep	Oct	Nov	Dec	Year
ATT	RTÉ One	99.9924	99.9999	99.9999	99.9999	99.9999	99.9999	99.9999	99.9999	99.9999	99.9999	99.9999	99.9999	99.9993
	RTÉ Two	99.9999	99.9916	99.9999	99.9999	99.9999	99.9999	99.9999	99.9999	99.9999	99.9999	99.9999	99.9999	99.9992
	TV3	99.9999	99.9999	99.9841	99.9999	99.9999	99.9999	99.9999	99.9999	99.9999	99.9999	99.9999	99.9999	99.9986
	TG4	99.9999	99.9999	99.9999	99.3284	99.9999	99.9999	99.9999	99.9999	99.9999	99.9999	99.9999	99.9999	99.9439
DTT	Mux 1				99.9999	99.9999	99.2358	99.9999	99.9999	99.9999	99.9999	99.9999	99.9999	99.9150
	Mux 2				99.9999	99.9999	99.9999	99.8654	99.9999	99.9999	99.9999	99.9999	99.9999	99.9650
	Mux 3				99.9999	99.9999	99.9999	99.9999	99.9756	99.9999	99.9999	99.9999	99.9999	99.9972
	Mux 4				99.9999	99.9999	99.9999	99.9999	99.9999	99.9999	99.9962	99.9999	99.9999	99.9995
Radio	RTÉ Radio 1	99.9999	99.9999	99.9999	99.9999	99.9999	99.9999	99.9999	99.9999	99.9653	99.9999	99.9999	99.9999	99.9970
	RTÉ 2FM	99.9999	99.9999	99.9999	99.9999	99.9999	99.9999	99.9999	99.9999	99.9999	99.9423	99.9999	99.9999	99.9951
	RTÉ RnaG	99.9999	99.9999	99.9999	99.9999	99.9999	99.9999	99.9999	99.9999	99.9999	99.9999	99.8642	99.9999	99.9886
	RTÉ Lyric	99.9999	99.9999	99.9999	99.9999	99.9999	99.9999	99.9999	99.9999	99.9999	99.9999	99.9999	99.9756	99.9979
	Today FM	99.9999	99.9999	99.9999	99.9999	99.9999	99.9999	99.9999	99.9999	99.9999	99.9999	99.9999	99.9782	99.9981

Monthly Service Availability Figures (Excluding Electricity Supply Outages)

2009		Jan	Feb	Mar	Apr	May	Jun	Jul	Aug	Sep	Oct	Nov	Dec	Year
ATT	RTÉ One	99.9924	99.9999	99.9999	99.9999	99.9999	99.9999	99.9999	99.9999	99.9999	99.9999	99.9999	99.9999	99.9993
	RTÉ Two	99.9999	99.9916	99.9999	99.9999	99.9999	99.9999	99.9999	99.9999	99.9999	99.9999	99.9999	99.9999	99.9992
	TV3	99.9999	99.9999	99.9841	99.9999	99.9999	99.9999	99.9999	99.9999	99.9999	99.9999	99.9999	99.9999	99.9986
	TG4	99.9999	99.9999	99.9999	99.3284	99.9999	99.9999	99.9999	99.9999	99.9999	99.9999	99.9999	99.9999	99.9439
DTT	Mux 1				99.9999	99.9999	99.2358	99.9999	99.9999	99.9999	99.9999	99.9999	99.9999	99.9150
	Mux 2				99.9999	99.9999	99.9999	99.8654	99.9999	99.9999	99.9999	99.9999	99.9999	99.9650
	Mux 3				99.9999	99.9999	99.9999	99.9999	99.9756	99.9999	99.9999	99.9999	99.9999	99.9972
	Mux 4				99.9999	99.9999	99.9999	99.9999	99.9999	99.9999	99.9962	99.9999	99.9999	99.9995
Radio	RTÉ Radio 1	99.9999	99.9999	99.9999	99.9999	99.9999	99.9999	99.9999	99.9999	99.9653	99.9999	99.9999	99.9999	99.9970
	RTÉ 2FM	99.9999	99.9999	99.9999	99.9999	99.9999	99.9999	99.9999	99.9999	99.9999	99.9423	99.9999	99.9999	99.9951
	RTÉ RnaG	99.9999	99.9999	99.9999	99.9999	99.9999	99.9999	99.9999	99.9999	99.9999	99.9999	99.8642	99.9999	99.9886
	RTÉ Lyric	99.9999	99.9999	99.9999	99.9999	99.9999	99.9999	99.9999	99.9999	99.9999	99.9999	99.9999	99.9756	99.9979
	Today FM	99.9999	99.9999	99.9999	99.9999	99.9999	99.9999	99.9999	99.9999	99.9999	99.9999	99.9999	99.9782	99.9981

## 12 Reference Documents

ITU-R Rec 647 or S/PDIF	AES/EBU Signal Format.
ITU-T Rec J.41	Companded Mode resolution.
ITU-T Rec J.17	Pre/De-Emphasis.
DIN 45 403	Intermodulation.
CCIR Rec 468-4	"Measurement of Audio frequency noise voltage levels in Sound Broadcasting. "
CCIR Rec 450-1	"Transmission Standards for FM Sound Broadcasting at VHF."
ETS 300 384(CCIR Rec 450)	VHF FM Sound Broadcasting Transmitters.

### 13.0 Abbreviations

ATDI	Advanced Topographic Development & Images Limited
ASI	Asynchronous Serial Interface
BAI	Broadcasting Authority of Ireland
FM	Frequency Modulated
NMC	Network Monitoring Centre
RDS	Radio Data System
SCADA	Supervisory Control and Data Acquisition
STM-1	Synchronous Transport Module - a microwave radio circuit
VHF	Very High Frequency

**TABLE 1 Site Data**

SITES	COUNTY	Details							
		Collocation space for Transmitters	Electrical infrastructure	Combined into 2rn Broadcast antenna	Availing of Antenna Hosting	Distribution Service Presentation	Antenna Polarity H = Horizontal V = Vertical	Electricity Backup Generator	2 Stack Antenna
1 Clermont Carn	Louth	Yes	Yes	Yes	Yes	Yes	V	Yes	Yes
2 Kippure	Wicklow	Yes	Yes	Yes	Yes	Yes	V	Yes	Yes
3 Maghera	Clare	Yes	Yes	Yes	Yes	Yes	V	Yes	Yes
4 Mt Leinster	Carlow	Yes	Yes	Yes	Yes	Yes	V	Yes	Yes
5 Mullaghanish	Cork	Yes	Yes	Yes	Yes	Yes	V	Yes	Yes
6 Spur Hill	Cork	Yes	Yes	Yes	Yes	Yes	V	Yes	Yes
7 Truskmore	Sligo	Yes	Yes	Yes	Yes	Yes	V	Yes	Yes
8 Castlebar	Mayo	Yes	Yes	Yes	Yes	No	V	No	Yes
9 Clonmel	Waterford	Yes	Yes	Yes	Yes	No	V	No	Yes
10 Crosshaven	Cork	Yes	Yes	Yes	Yes	No	V	No	Yes
11 Dungarvan	Waterford	Yes	Yes	Yes	Yes	No	V	Yes	Yes
12 Greystones	Wicklow	Yes	Yes	Yes	Yes	No	V	No	Yes
13 Holywell Hill	Donegal	Yes	Yes	Yes	Yes	No	V	Yes	Yes
14 Knockmoyle	Kerry	Yes	Yes	Yes	Yes	No	V	Yes	Yes
15 Monaghan	Monaghan	Yes	Yes	Yes	Yes	No	V	No	Yes
16 Suir Valley	Kilkenny	Yes	Yes	Yes	Yes	No	V	Yes	Yes
17 Woodcock Hill	Clare	Yes	Yes	Yes	Yes	Yes	V	Yes	Yes
18 Achill	Mayo	Yes	Yes	Yes	Yes	No	V	Yes	Yes
19 Clifden	Galway	Yes	Yes	Yes	Yes	No	V	Yes	Yes
20 Collins Barracks	Cork	Yes	Yes	Yes	Yes	No	V	No	Yes
21 Fanad	Donegal	Yes	Yes	Yes	Yes	No	V	Yes	Yes
22 Kinsale	Cork	Yes	Yes	Yes	Yes	No	V	No	No
23 Moville	Donegal	Yes	Yes	Yes	Yes	No	V	Yes	Yes

**TABLE 2 - Points of Contact**

**Fault Response**

Service Providers Network Monitoring Centre (NMC)

Tel 1: 01 208 2259  
 Tel 2: 01 208 2685  
 Mob: 087 2423310  
 E-mail: nmc@2rn.ie

**Escalation Process**

The Service Provider

NMC Manager: David Mathews

Tel: 01 208 3095  
 Mob: 087 2940883  
 E-mail: dave.matthews@2rn.ie

Operations Manager: Ronan Dempsey

Mob: 087 9853655  
 E-mail: ronan.dempsey@2rn.ie

Executive Director: Mick Kehoe

Tel: 01 208 2249  
 Mob: 086 813 5979  
 E-mail: mick.kehoe@2rn.ie

Client

Head of Transmission:

Tel:  
 E-mail:

Head of Operations:

Tel:  
 E-mail:

Managing Director TV:

Tel:  
 E-mail:

**Routine Meetings**

Client Representative:

Name:  
 Tel:  
 Mob:  
 E-mail:

Service Provider Representative:

Name: John Clarke  
 Tel: 01 208 2858  
 Mob: 087 224 2009  
 E-mail: john.clarke@2rn.ie

**1.0 Note**

A detailed Reference Offer and Service Schedule for a fully managed national Longwave Service is available on request from the Service Provider.

The provision of a Reference Offer for a national Longwave Service is subject to the following;

- 1 The availability of a national Longwave Broadcasting Licence,
- 2 The availability of an appropriately located site which would be suitable to facilitate the relevant infrastructure in order to provide the service and
- 3 A successful planning application to the relevant authorities to construct the relevant infrastructure.

## APPENDIX B

### TARIFFS

## 1.0 TARIFF PRICING MODEL

### 1.1 INTRODUCTION

The pricing model used by the Service Provider to derive charges for provision of national terrestrial broadcast transmission services has been developed to be consistent with the following core regulatory principles:

- **Causality:** Costs shall be ascribed in accordance with the activities that cause the cost (or revenue) to be incurred. This ensures that only those costs associated, either directly or indirectly, with providing a service are allocated to it. This reduces the potential for cross-subsidisation.
- **Objectivity:** Attribution must not benefit the access provider, any access seeker, service or business. It must be based on verifiable information, with the use of management estimates to calculate costs usually limited. As an example, any allocation of costs to digital services, rather than analogue services, will need to be clearly justified based on actual data that could be reviewed by external auditors.
- **Consistency:** Cost allocation methods, treatment of costs and the approach used to calculate tariffs need to be consistent from year to year.
- **Transparency:** Within a cost model, this implies that attributed items must be traceable back to their source and the elements that contribute to the cost of the service should be visible.

The Service Provider is subject to an obligation of cost-orientation of tariffs under section 10, Annex 1 of ComReg Decision D02/26 of 27 January 2026 and under Regulation 9(4) of the European Communities (Electronic Communications Networks and Services) (Access) Regulations of 2011, ComReg may require tariffs to be adjusted.

### 1.2 THE NETWORK COST MODEL

In accordance with the Service Providers obligation of cost-orientation under ComReg Decision D02/26 the inputs to the network cost model are the costs incurred by the Service Provider in providing network services to its Clients, including Digital Terrestrial Television (DTT), radio and third party customers. The cost inputs include:

- Operating expenditures (opex).
  - Relevant, efficiently incurred operating costs apportioned on a Fully Allocated Cost basis to users of the network.
- Capital costs (capex), including:
  - Depreciation on fixed assets.
    - Depreciation of Regulated Assets apportioned to regulated markets based on system usage.
  - A WACC-based return on asset values.

- Asset values on which a return is calculated is the Net Book Value of Regulatory Assets.

The modelling process for the allocation of opex and capex to broadcast customers is summarised below.

### Modelling process for allocation of costs

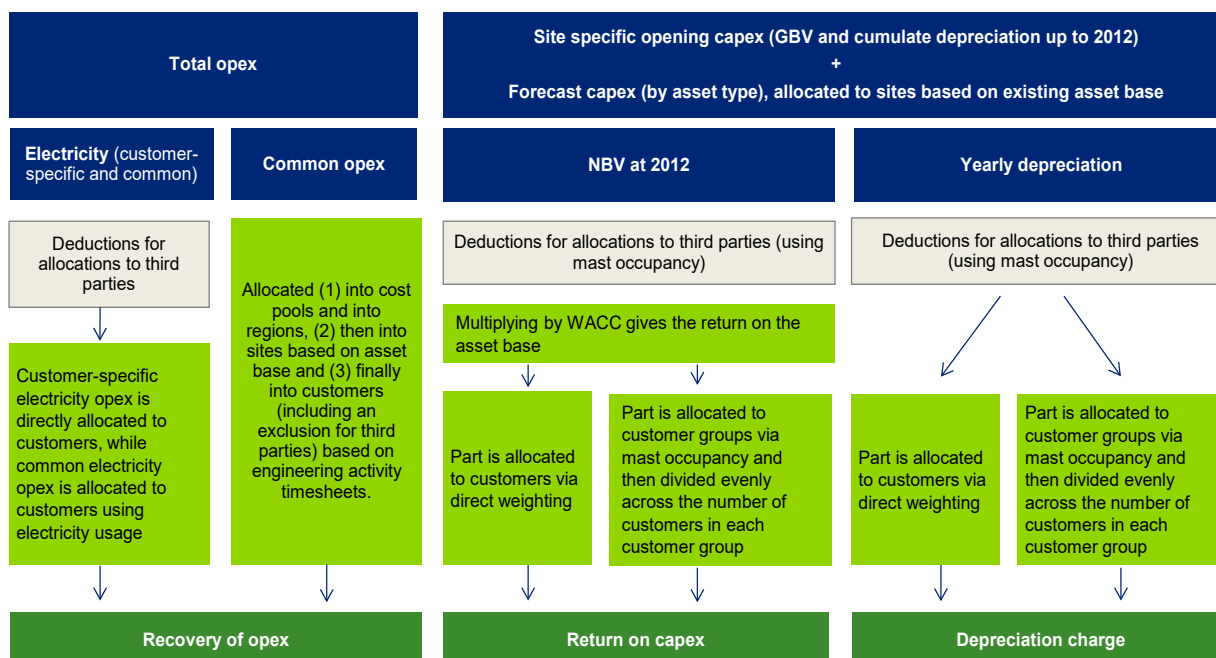

The charges derived are then calculated as:

**Recovery of operating cost + Recovery of depreciation+ Return on investment.**

Return on investment is in turn calculated as:

$$\mathbf{RAB \times WACC}$$

Where **RAB** is the Net Book Value of the Service Provider's investment in regulatory assets and;

**WACC** is the appropriate Weighted Average Cost of Capital, currently 6.99% as per ComReg Decision D10/20, and subsequent annual update 25/35 dated 12<sup>th</sup> June 2025.

## 2.0 TARIFF CALCULATION AND TARIFF LEVELS

### 2.1 CALCULATION

Subject to the specific access requirements of the Client the above cost model shall be appropriately applied to all reasonable requests from Broadcast Operators for Access to a fully managed national Broadcast Transmission Service or any element of a fully managed Broadcast Transmission Service on a disaggregated basis, namely:

- Co-location space for Clients' self-supplied Transmitter equipment,

- Combined access into the Service Providers National Broadcast antenna,
  - Electricity supply and back-up electrical generator where installed,
  - Telemetry services,
  - Microwave distribution service where available.
- Support Services

Other services, including but not limited to antennae hosting, requested by qualifying Broadcast Operators shall be priced with reference to the Service Providers current rate-card which is available on request following the execution of a Non Disclosure Agreement (NDA) as part of an access request process.

## **2.2 2026 INDICATIVE TARIFFS**

The applicable tariffs for services delivered in respect of Market A are derived from the Cost Model outlined above, subject to any adjustments that ComReg may direct. The Service Provider strictly reserves the right to amend or modify the Cost Model used to derive Tariffs including without limitation for the purpose of complying with the directions of a Competent Authority.

Applicable tariffs vary according to the total number of services being carried over the System as well as a Broadcaster's (either a Multiplex Operator or a FM Radio Broadcaster) specific requirements.

Accordingly, tariffs will vary depending on the additional equipment which may be required where a new service is added to the System. Tariffs will also vary depending on what enhancements to the existing power, distribution and other ancillary equipment, systems and services are required in order to achieve the specific requirements of the Client. The Tariffs specified below are indicative tariffs that are subject to change including adjustments further to directions of ComReg.

This Appendix B will be reviewed and updated in the light of any developments which may result in the addition of a service, or services, to the System, including in particular any licensing process commenced by the BAI pursuant to the Broadcasting Act 2009. Changes to this Appendix B will be notified to ComReg and published in draft form in accordance with section 9.4 of ComReg Decision D02/26, Annex 1.

<b>MARKET A</b>	
<b>SCHEDULE 101</b>	
<b>DTT Distribution and Transmission</b>	<b>INDICATIVE TARIFFS</b>
Fully managed distribution and transmission service for one national DTT Multiplex, with two national DTT multiplexes on the System, each with population coverage in the order of 98% (outdoor, rooftop aerial).	€ 5,208,080
Fully Managed distribution and transmission service for one national DTT Multiplex, with three national DTT multiplexes on the System, each with population coverage in the order of 98% (outdoor, rooftop aerial), <b>estimated</b> and subject to capacity availability, specific technical requirements, and the population coverage requirements of a DTT Multiplex Operator.	€ 4,045,000 to € 4,345,000

<b>MARKET A</b>	
<b>SCHEDULE 201</b>	
<b>FM Distribution and Transmission</b>	<b>INDICATIVE TARIFFS</b>
Fully managed distribution and transmission service for a national FM service, on the basis of a total of 4 national services with population coverage comprised between 94% and 95% (indoor aerial).	€ 1,140,959 to € 1,159,725
Additional / 5 <sup>th</sup> national FM service.	Depending on the FM Broadcaster's specific technical requirements and population coverage (there are capacity limitations with some of the Service Provider's FM antenna systems).

<b>MARKET A</b>	
<b>SCHEDULE 301</b>	
<b>ACCESS</b>	
Co-location Services and access to the antenna systems and other infrastructure (excluding electricity consumption).	Subject to capacity availability and limitations and technical and location requirements.  <i>Refer to the 2rn "Process Manual -- 2rn Co-locations Network Access Services"</i>
Additional facilities and services.	Subject to capacity availability and limitations and technical and location requirements.  <i>Refer to the 2rn "Process Manual -- 2rn Co-locations Network Access Services"</i>
Electricity consumption.	Actual consumption measured and charged retrospectively

<b>MARKET A</b>	
<b>SCHEDULE 401</b>	
<b>ACCESS</b>	
Co-location Services and access to the antenna systems and other infrastructure and national FM Distribution Service (excluding electricity consumption).	Subject to capacity availability and limitations and technical and location requirements.  <i>Refer to the 2rn "Process Manual -- 2rn Co-locations Network Access Services"</i>
Additional facilities and services.	Subject to capacity availability and limitations and technical and location requirements.  <i>Refer to the 2rn "Process Manual -- 2rn Co-locations Network Access Services"</i>
Electricity consumption.	Actual consumption measured and charged retrospectively

## **APPENDIX C**

### **ROLL OUT**



**1.0 SERVICE DISCRIPTION**

1.1 FULLY MANAGED

To be advised

1.2 ACCESS

*To be advised*

**2.0 TIMELINES**

*To be advised*